

متقن محمد بوضياف -الرباحية- ولاية سعيدة  
marouaneouldkada@gmail.com

من اعداد :

الاساتدة - جنيدى الزهرة  
- ولد قادة نجادى

تحت اشراف السيد مكاوي محمد

# معمل اعادة تصنيع الحديد

طرح الإشكال:

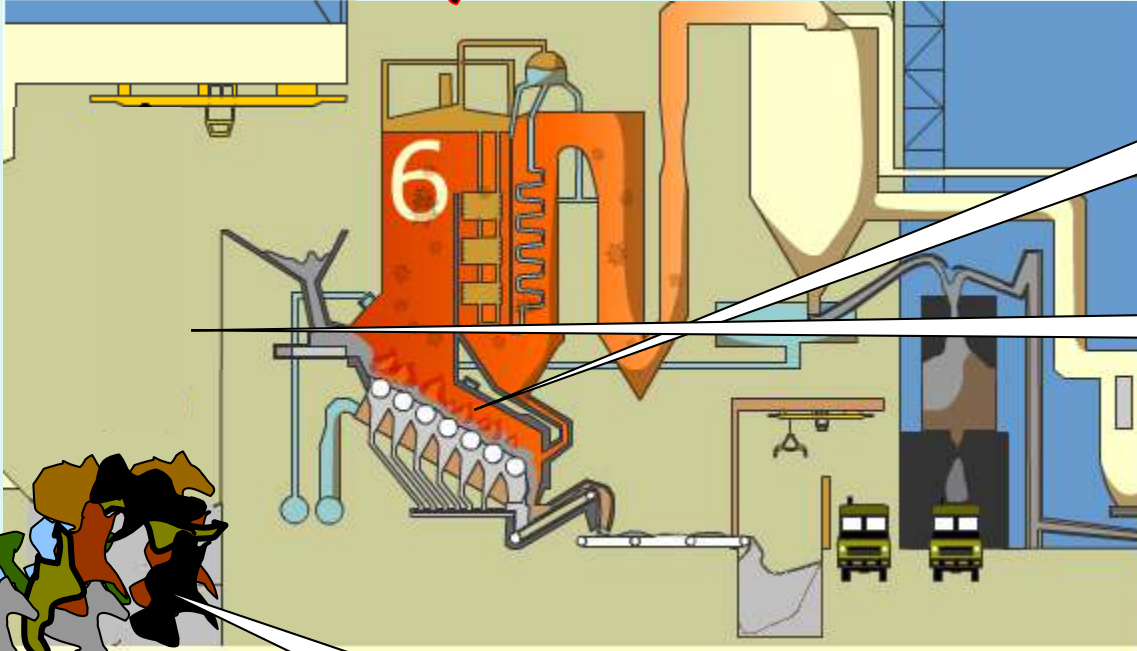

درجة حرارة الفرن  
3000°

الارتفاع 6m

... اه الحل بسيط  
... سأستعمل ...

انها ثقيلة !!!  
كيف استطيع ان ارفع  
هذه القطع الحديدية??

... كم هو مريحة  
التكنولوجية

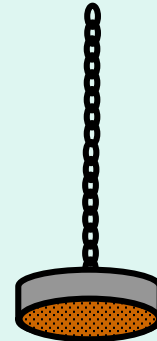

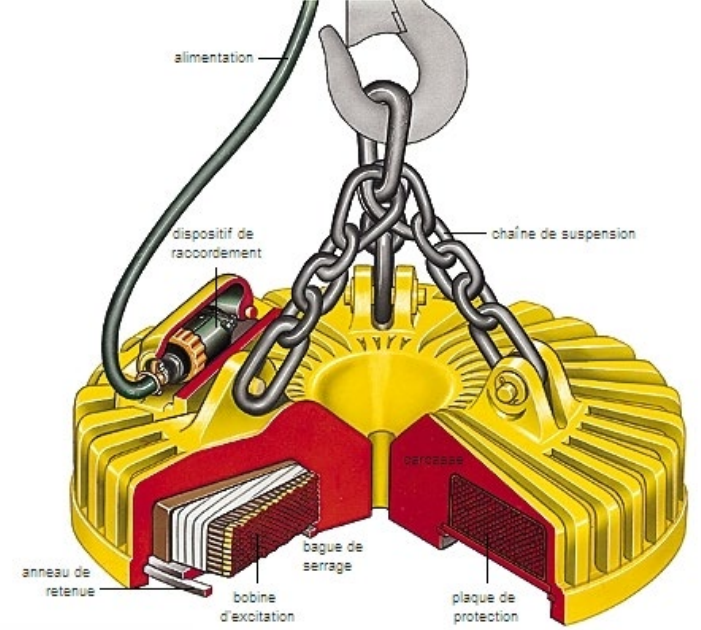

## استعمالات المغناطيس



# استعمالات المغناطيس





## استعمالات المغناطيس

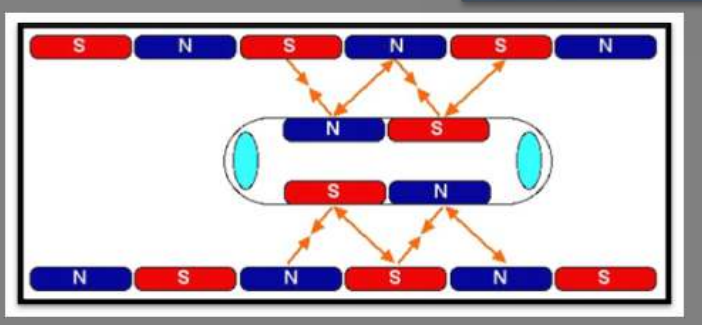



SUSPENSION  
EXTERNE

MEMBRANE

BOBINE MOBILE

AIMANT

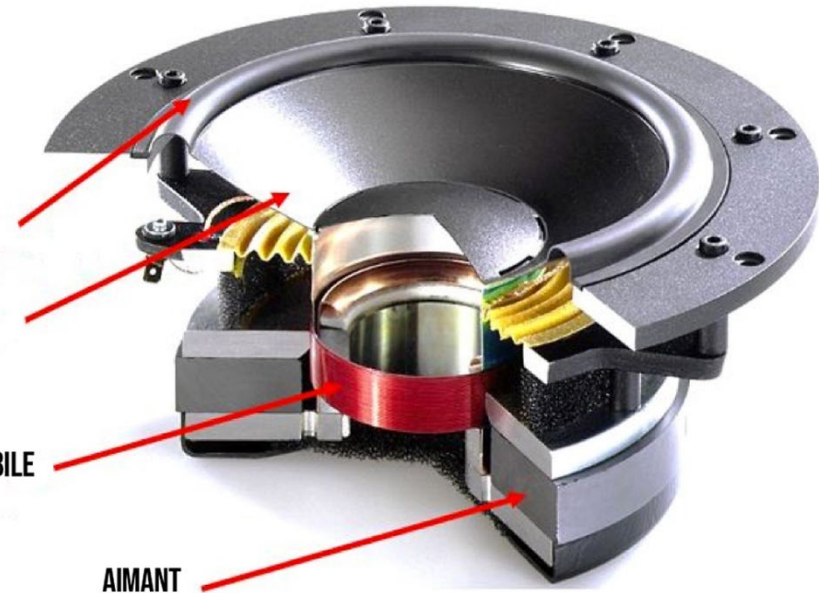

## استعمالات المغناطيس



Vue de dessous



Vue du dessus

# الدارات المغناطيسية

## 1. مصادر الحقل المغناطيسي

للحصول على حقل مغناطيسي هناك طريقتان :

أ. مغناطيس طبيعي .  $Fe_3O_4$

ب. مغناطيس اصطناعي : ويتم الحصول عليه بواسطة تمرير تيار كهربائي في وشيعة .



- مغناطيس طبيعي -

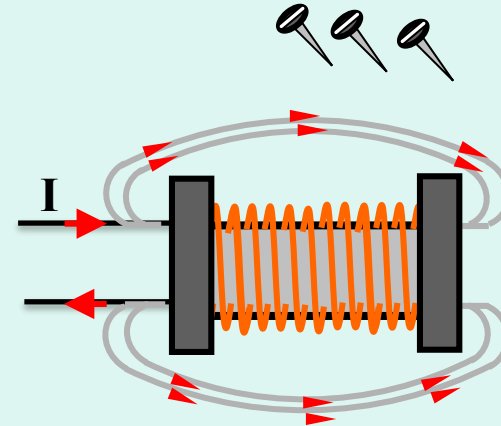

- مغناطيس اصطناعي -

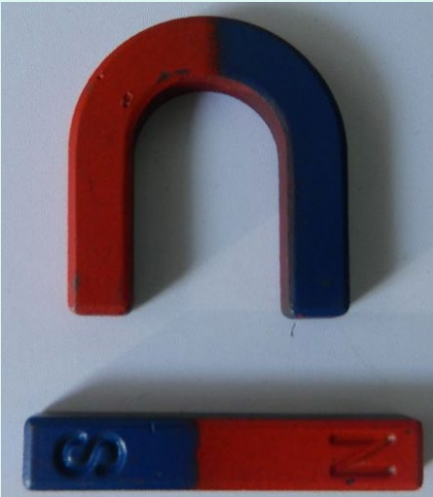

2- الحقل المغناطيسي : نضع إبرة مغناطيسية أمام مغناطيس فنلاحظ أن الإبرة **تتجذب** نحو المغناطيس ثم نبدأ في إبعاد المغناطيس تدريجيا عن الإبرة فنلاحظ أن تأثير المغناطيس يصبح **ضعيفا** كلما ابتعدنا أكثر إلا أن **ينعقد** تأثيره .

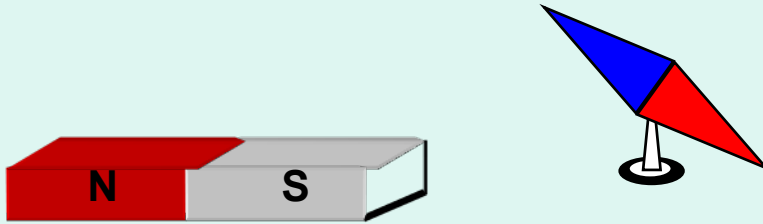
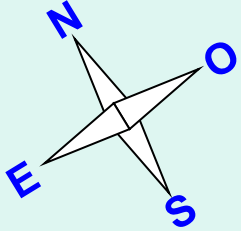

وعليه فإن **مساحة** تأثير المغناطيس على الإبرة تدعى **بالحقل المغناطيسي** ووحده **TESLA (T)** .  
أما رمزه **( H )** .

### 3- التحريض المغناطيسي :

- إذا حاولنا زحزحت الابرّة عن موضعها فإن الابرّة تتدحرج حول حاملها ثم بعد ذلك ترجع الى وضعها الأول أي أن **للحقل المغناطيسي منحى معين** .

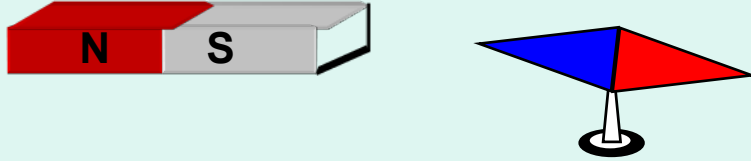

- أما إذا حولنا قلب إتجاه الابرّة فإن الابرّة سوف ترجع الى وضعه السابق أي أن **للحقل المغناطيسي اتجاه معين** .

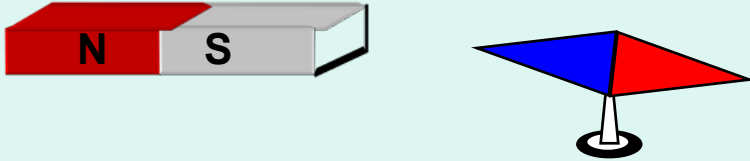

- أما إذا قربنا الابرّة مسافة أقرب من الاولى ثم نزحزحها عن موضعها فإن تدحرجتها يكون أبط من الاول أي أن **للحقل المغناطيسي شدة معينة** . كل هذه الخواص نعبر عنها بالتحريض المغناطيسي

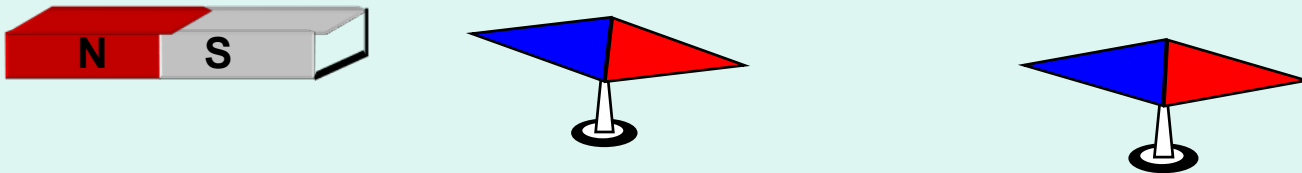

4- التدفق المغناطيسي : هو الناظم على مساحة حقل مغناطيسي ما ووحدته ويبر **WEBER** .

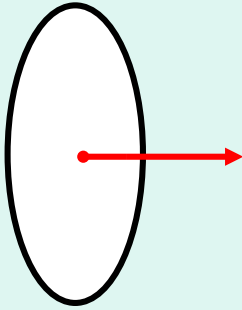

$$\Phi = B \cdot S$$

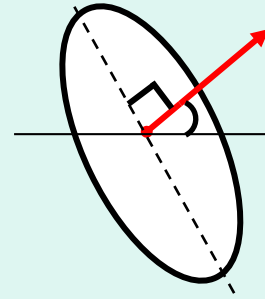

$$\Phi = B \cdot S \cdot \cos\phi$$

## 5- الدارة المغناطيسية :

1- تعريف: ان الغاية من الدارة الكهربائية هو تأمين مرور التيار الكهربائي ، فإن الغاية من الدارة المغناطيسية هو تأمين مرور التدفق المغناطيسي وهي توجد على عدة أشكال .

2- أنواع الدارات المغناطيسية : ومنها عدة اشكال :

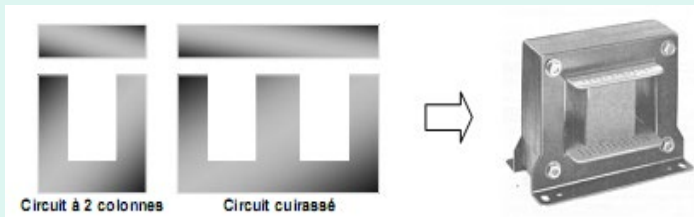
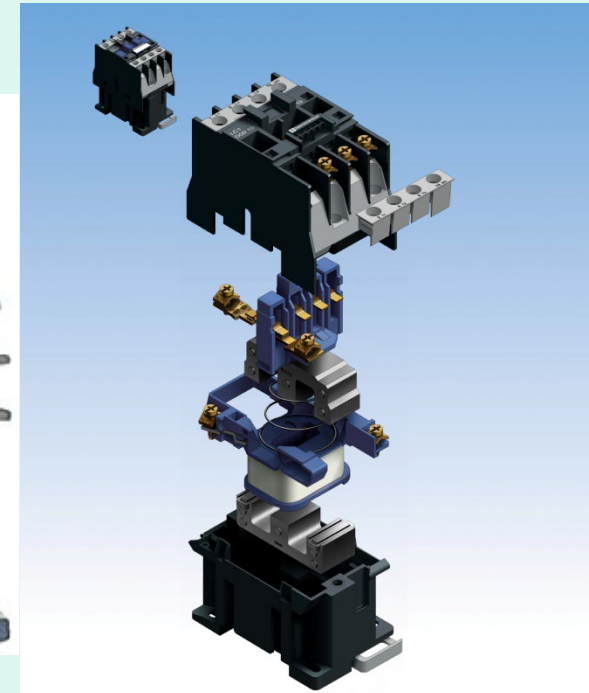
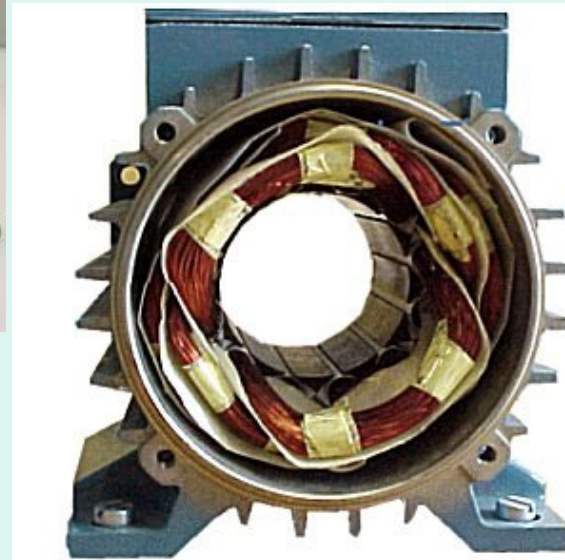
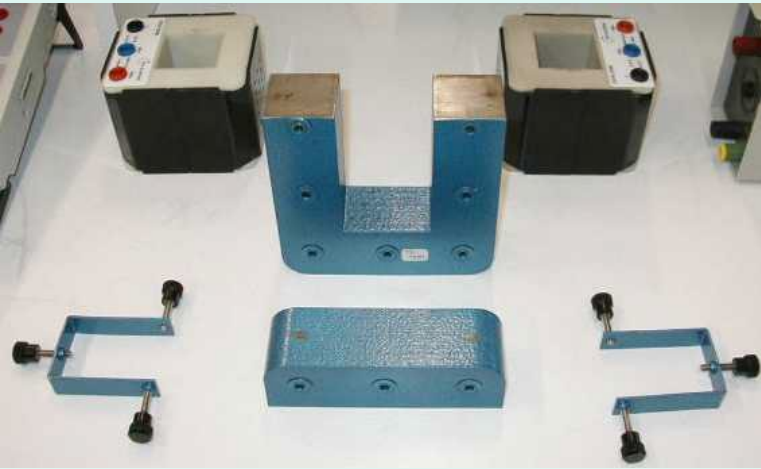
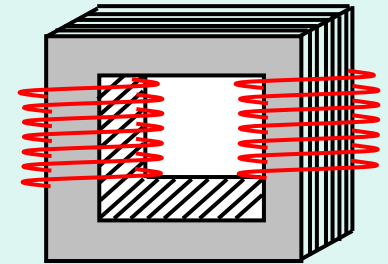
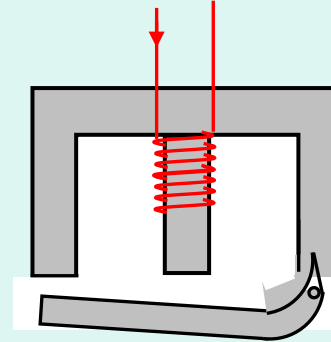
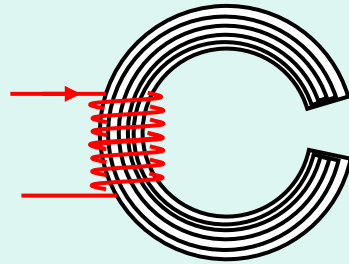
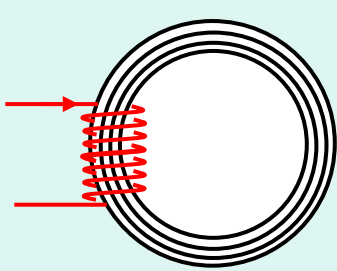

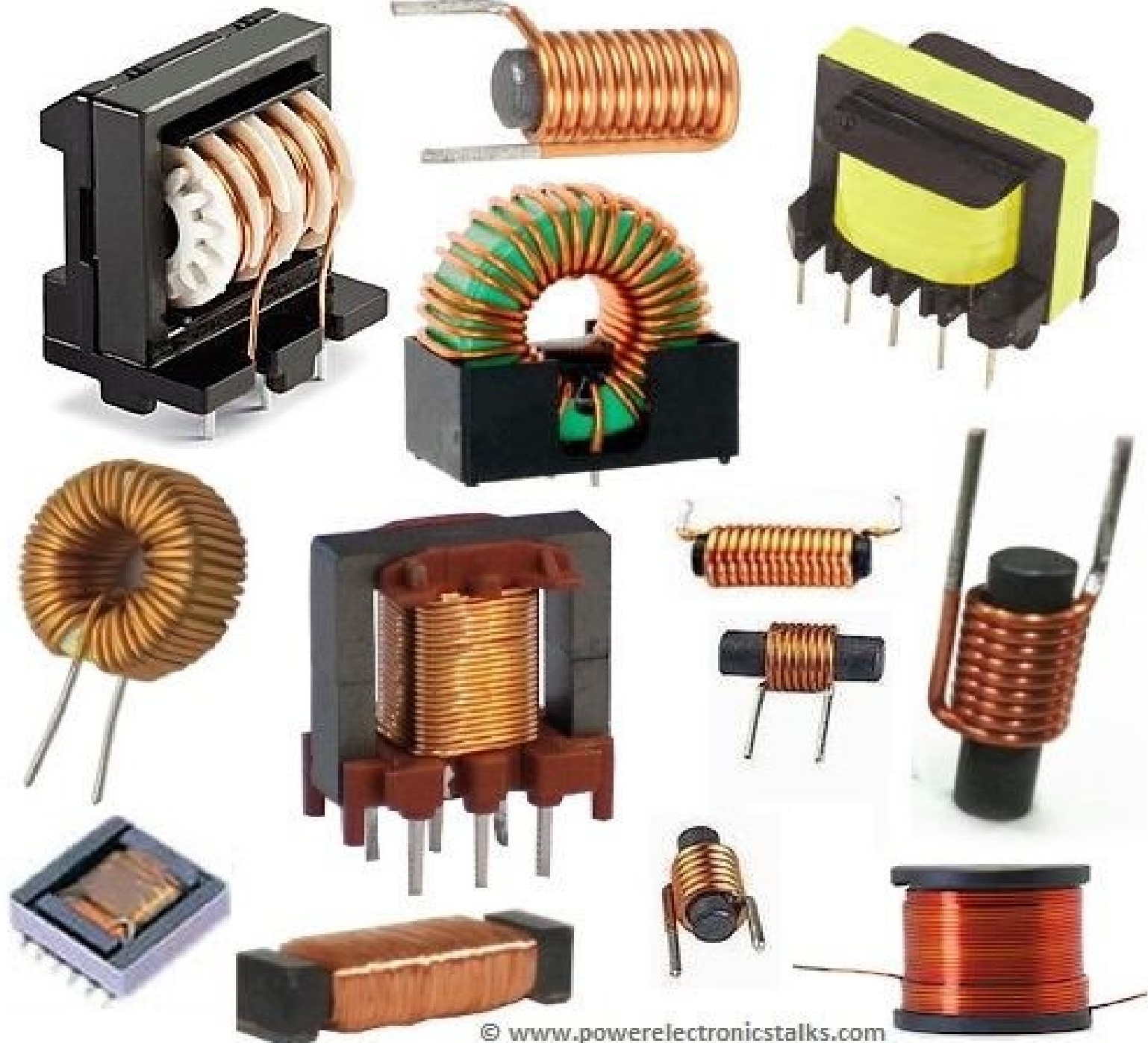

### 3- تطبيقات الدارة المغناطيسية : من بين تطبيقات الدارة المغناطيسية هي المرحل الكهرومغناطيسي (Relais électromagnétique).

#### 1- المرحل الكهرومغناطيسي :

هو عبارة عن **كهرومغناطيس** يسمح بالتحكم في **فتح وغلقة** كهربائية تحوي أجهزة كهربائية ذات استطاعة معتبرة حيث يحتوي على **دارة تحكم وماسات لدارة الاستطاعة**

#### 1-1 التركيب :

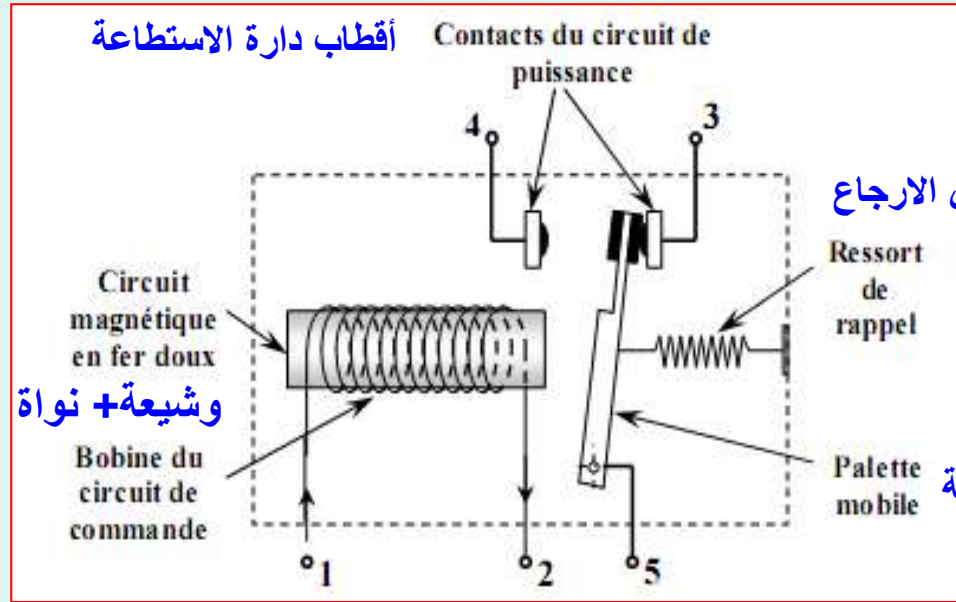

شبيعة + نواة

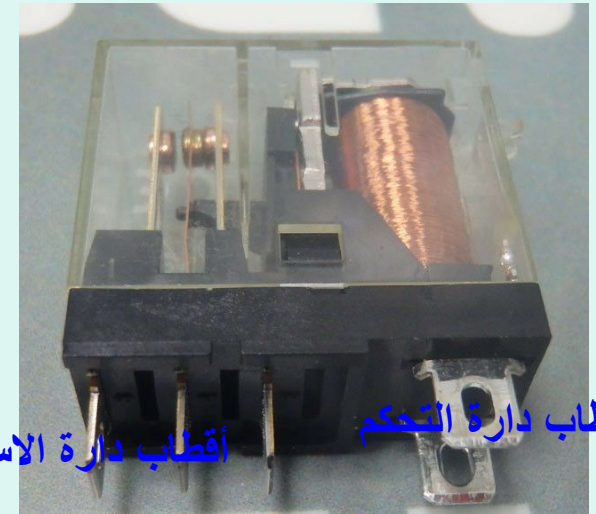

أقطاب دارة التحكم

أقطاب دارة الاستطاعة

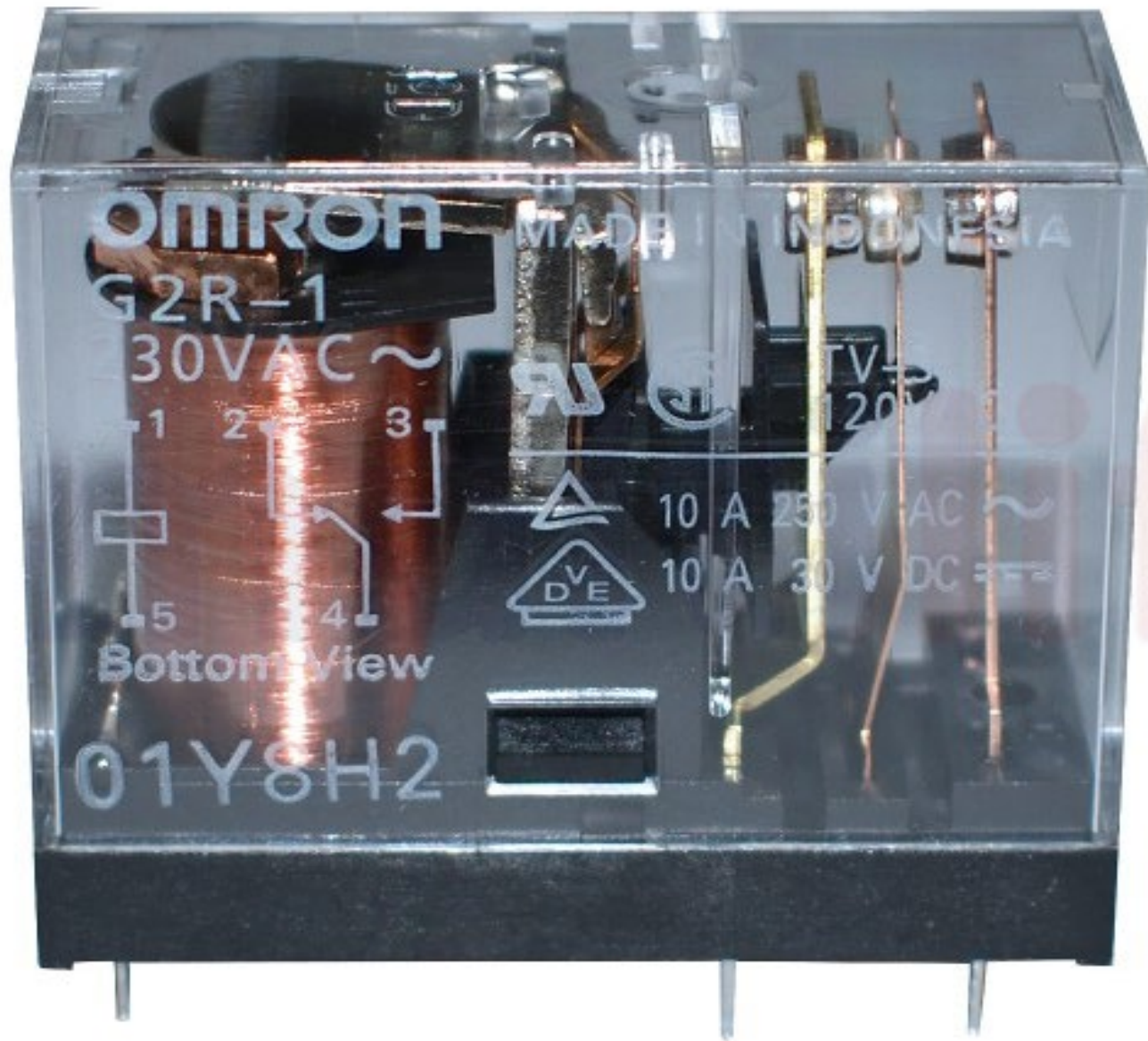

OMRON

MADE IN INDONESIA

G2R-1

230VAC ~

1 2 3



Bottom View



10 A 250 V AC ~

10 A 30 V DC



01Y8H2

EXEMPLE DE RELAIS 12 V, 2 CONTACTS TRAVAIL

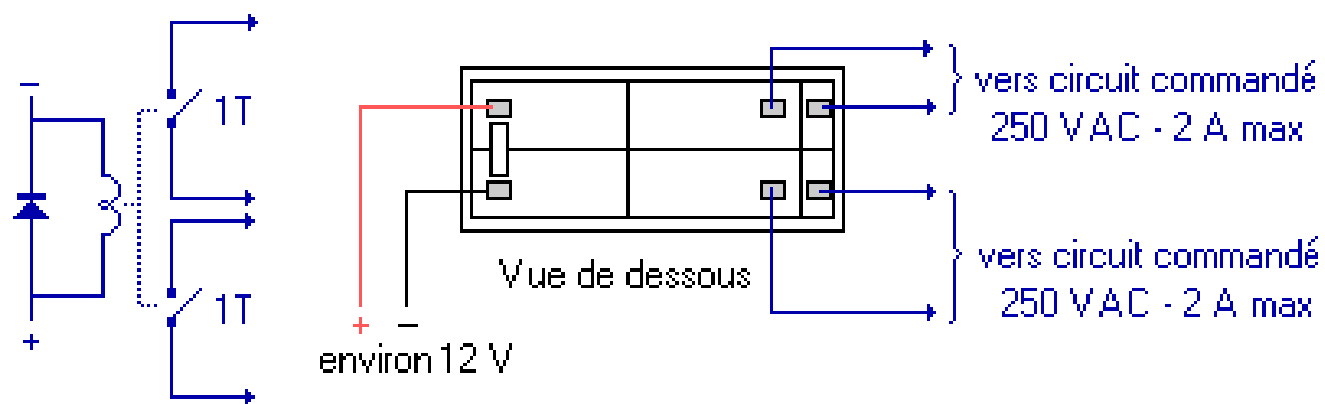
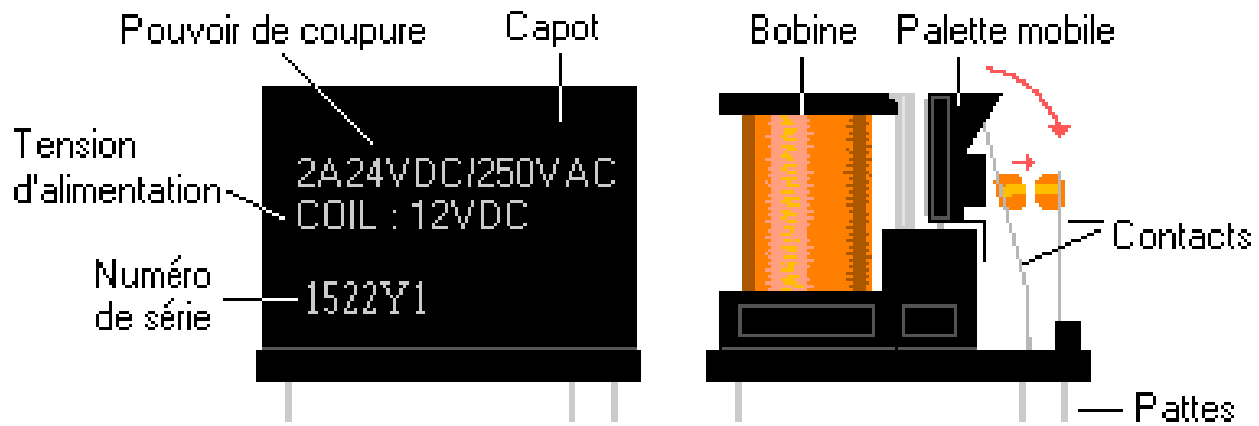

**2-1 مبدأ التشغيل :** عند الضغط على الزر الضاغط **تتمغنط الوشيعية** في **دائرة التحكم تيار ضعيف فتجذب** الصفيحة فتغلق الماسة في **دائرة الاستطاعة تيار معتبر** فتغلق الدارة على أجهزة الاستعمال ذات الاستطاعة المعتبرة وعند فقد المغنطة **ترجع الصفيحة** لوضعيتها الأولى بفعل **نابض الارجاع.**

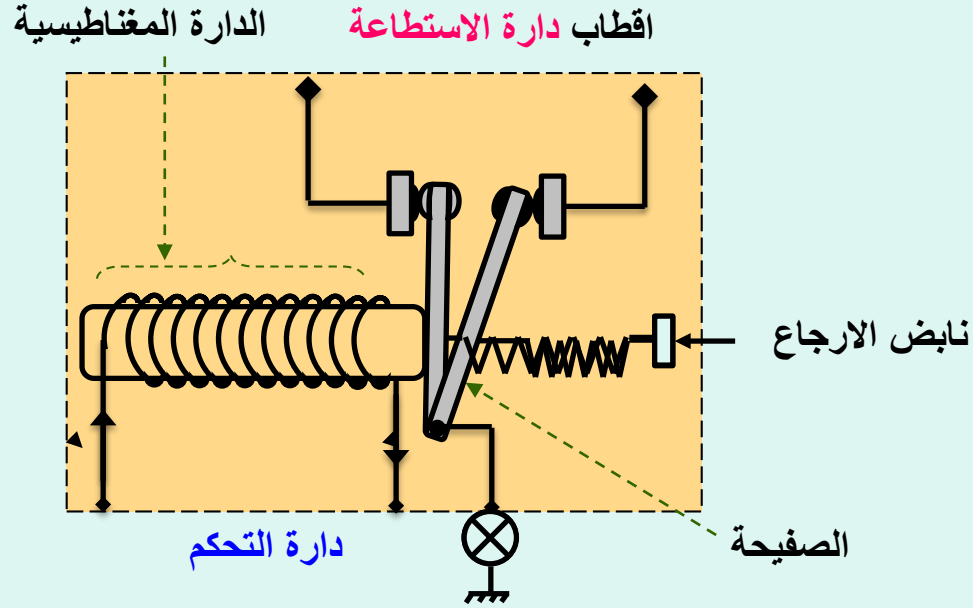

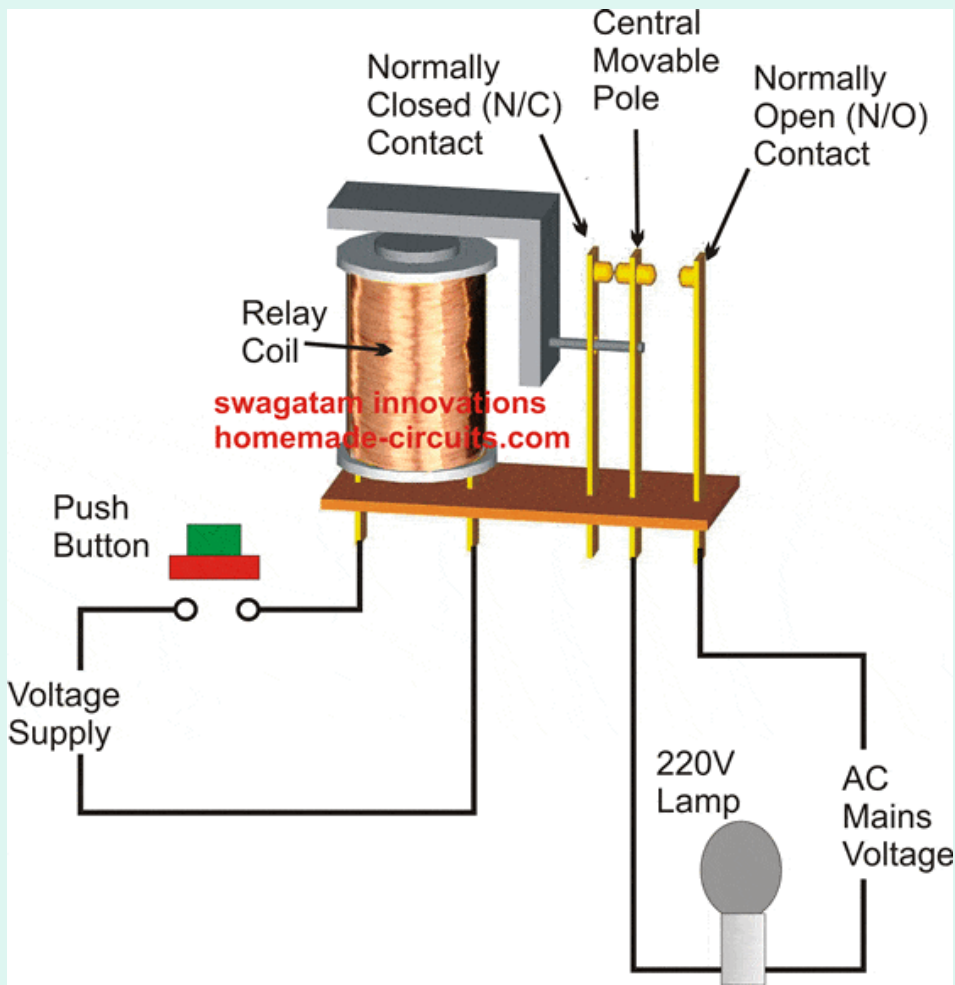

مبدأ التشغيل



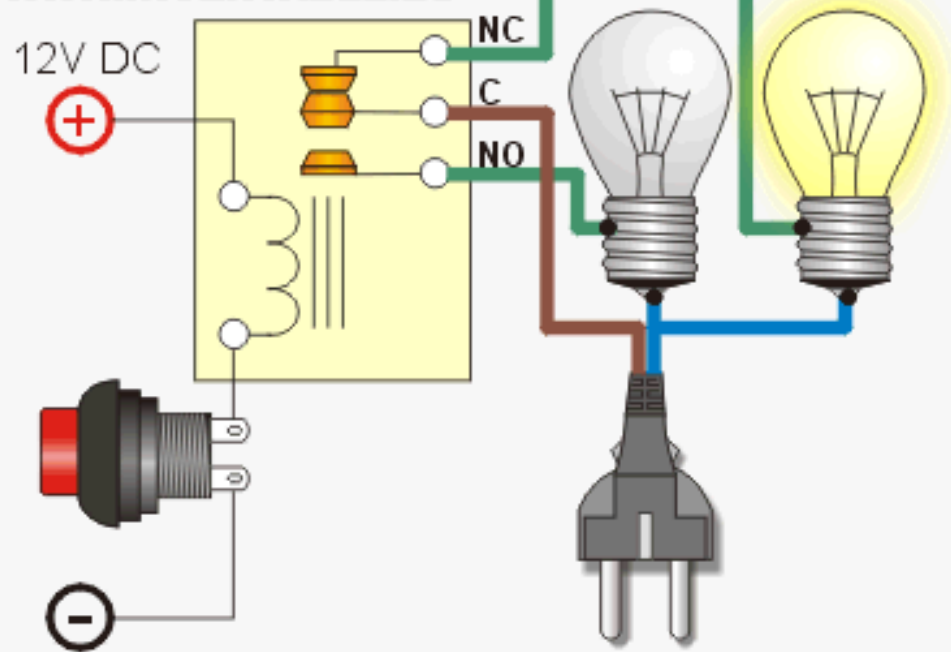
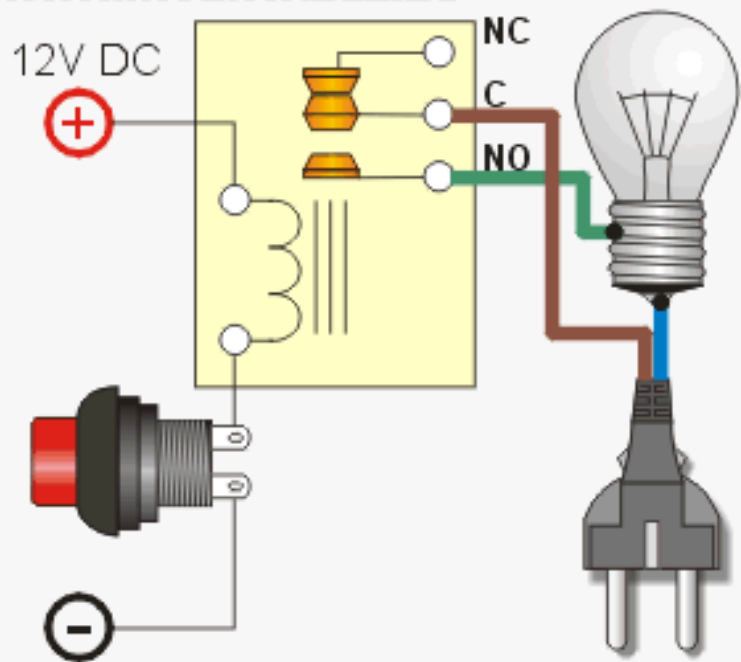

مبدأ التشغيل

### 3-1 الرمز :

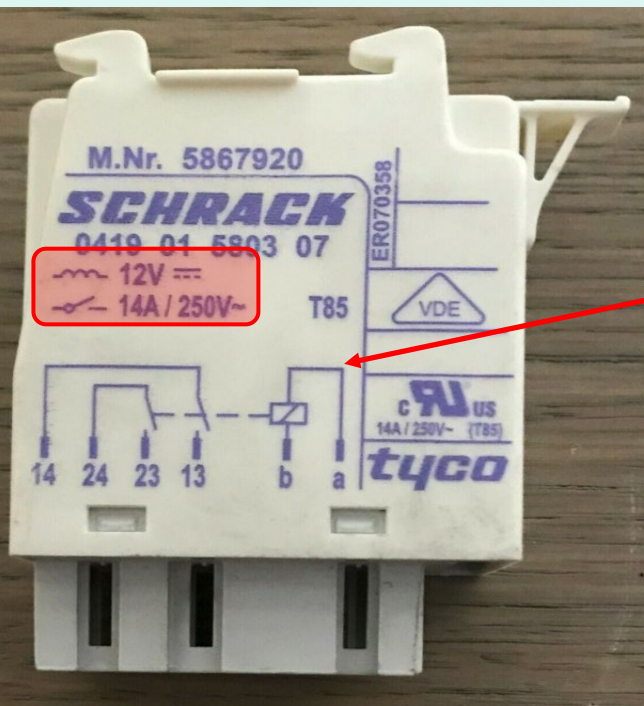
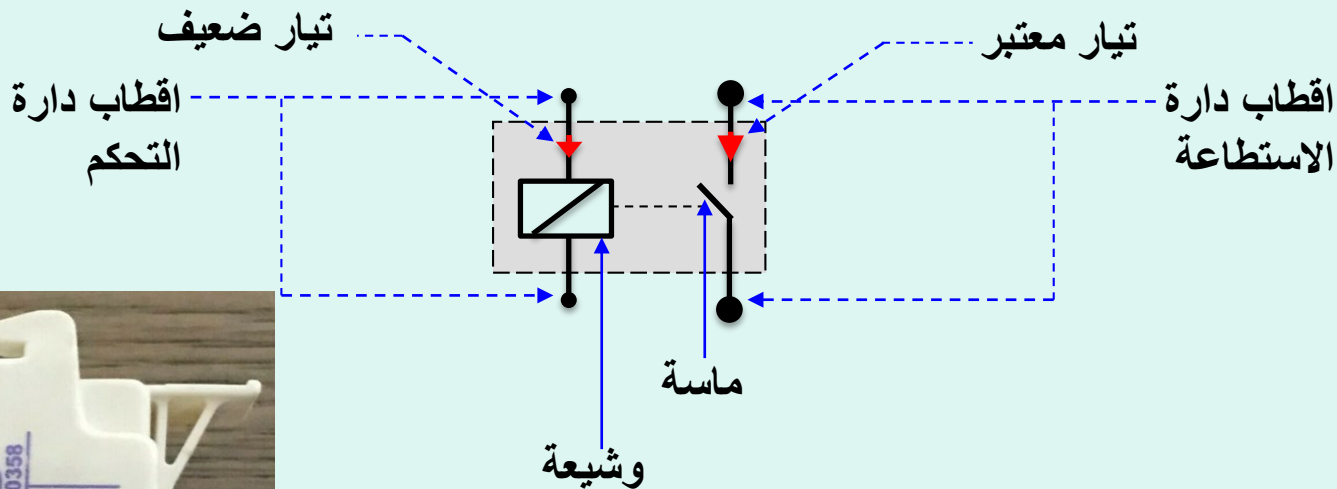

مرحل آلة الغسيل

### 4-1 تركيب المرحل في دارة كهربائية :

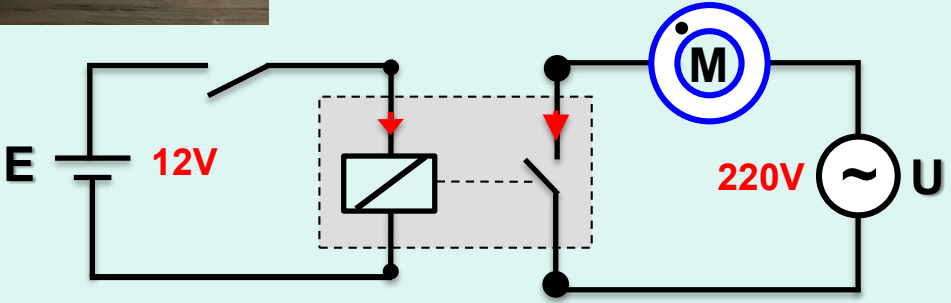



توتر ضعيف 6V

توتر معتبر 250V

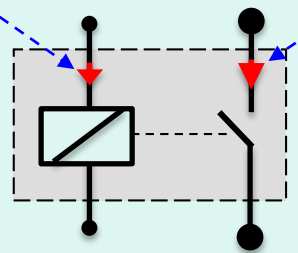

وشيعة

ماسة

## 6- قانون لابلاس :

**1- تعريف :** إذا مر تيار كهربائي ( $I$ ) في ناقل أومي خاضع لمجال مغناطيسي ( $H$ )، فإنه يخضع الى قوة ( $F$ ) تؤدي الى تحريكه تدعى هذه قوة لابلاس وهذا هو **مبدأ المحركات** .

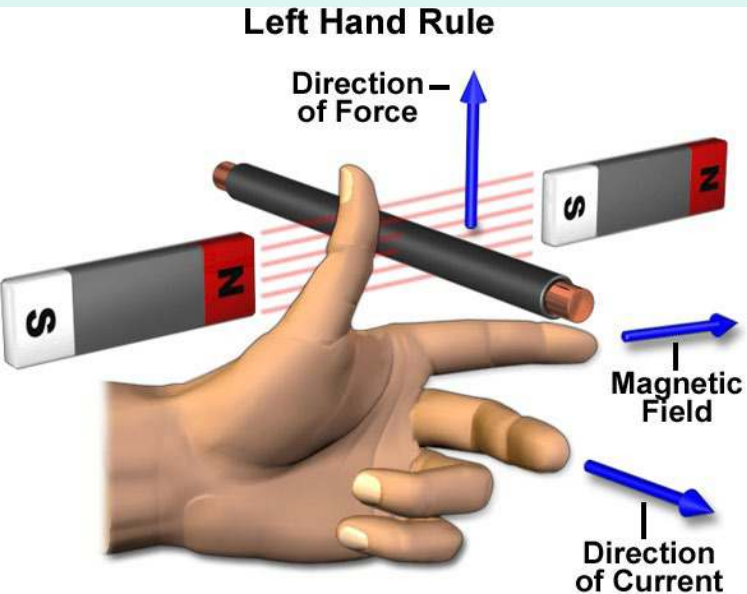
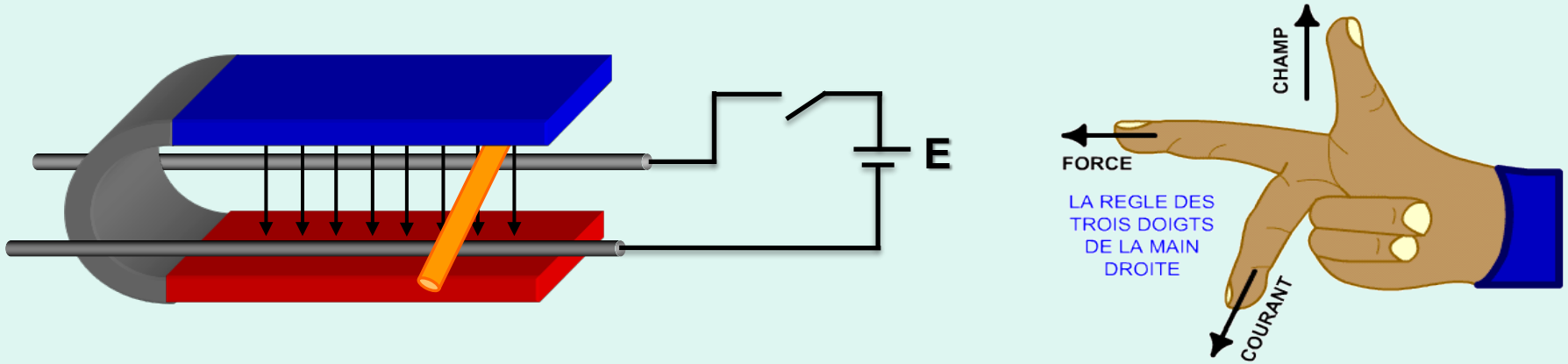

- الابهام : يشير إلى الحقل المغناطيسي .
- الوسطى : تشير الى اتجاه التيار .
- السبابة : تشير الى اتجاه القوة .

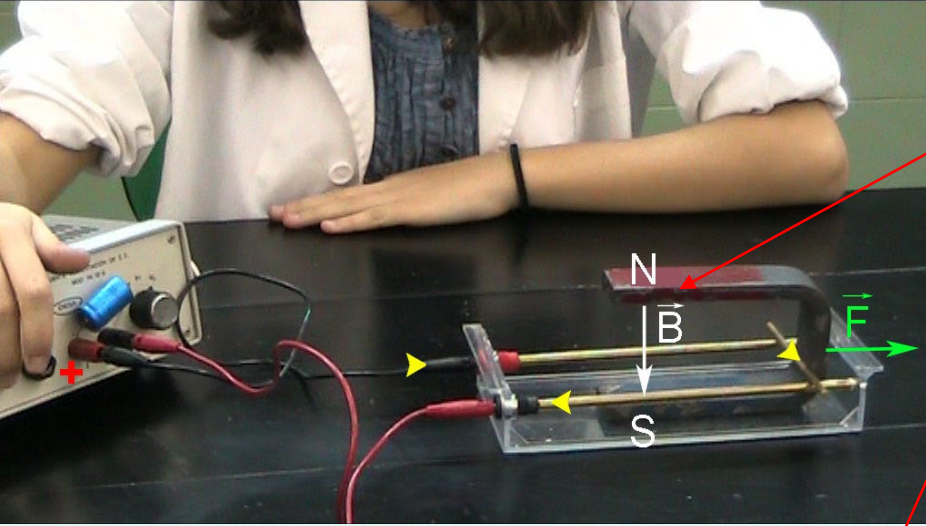

تغير اتجاه الحقل

تغير اتجاه الحقل

تغير اتجاه التيار

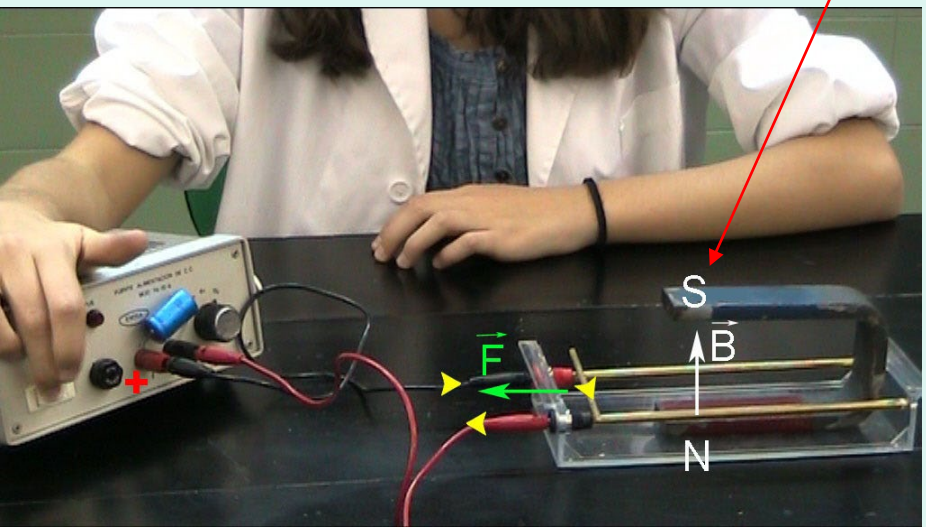
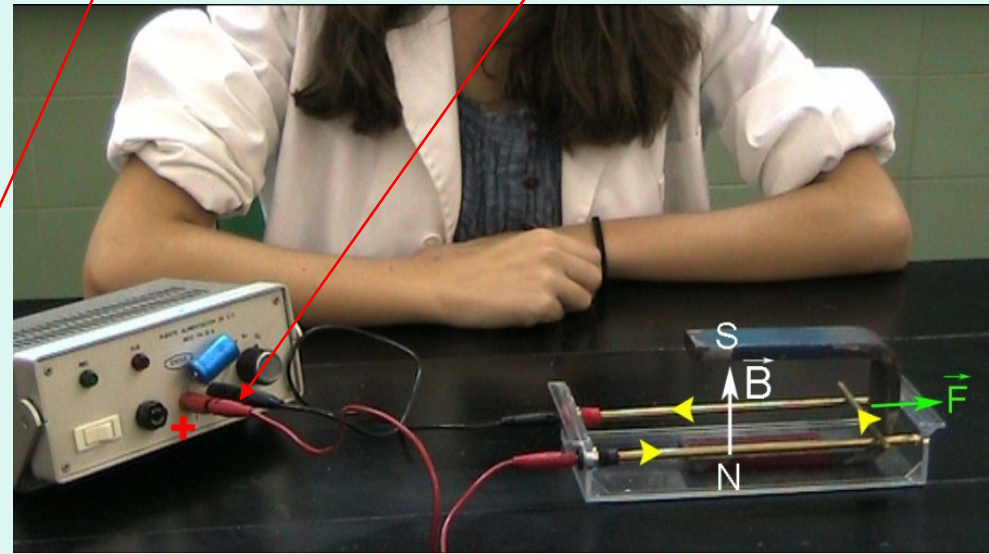

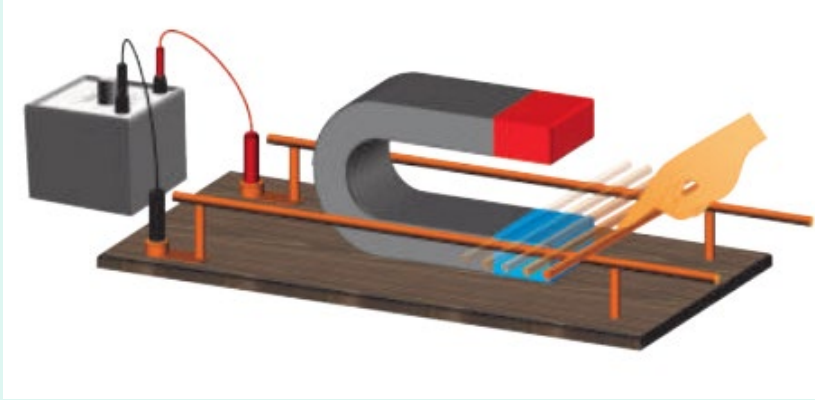

a) La tige est déplacée vers la droite

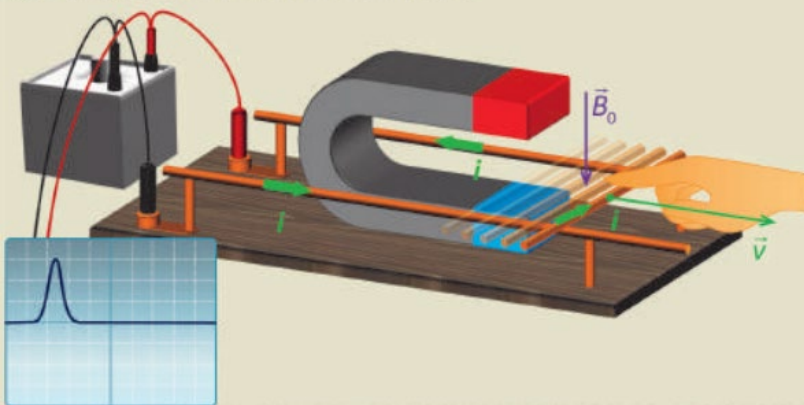

b) La tige est déplacée vers la gauche

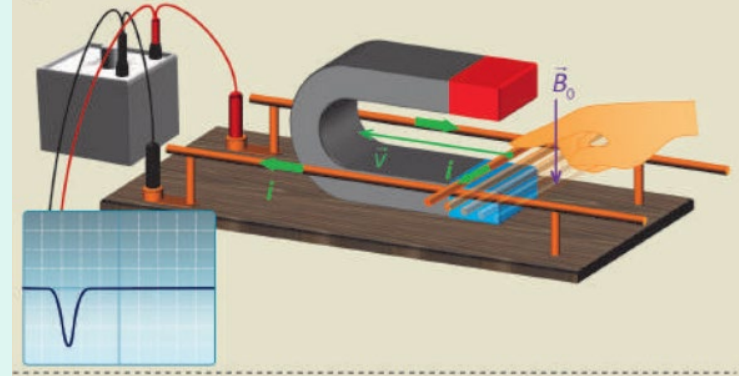

## 7- قانون فاراداي :

**1- تعريف ::** اذا أخذنا وشيعة متصلة بجهاز القلفانومتر ونقرب منها مغناطيس أي انها تصبح خاضعة لمجال مغناطيسي فإنها تتولد فيها قوة محرركة كهربائية ( E ) وهذه هو **مبدأ المولدات** وتعطى بالعلاقة

$$E = - \frac{d\phi}{dt}$$

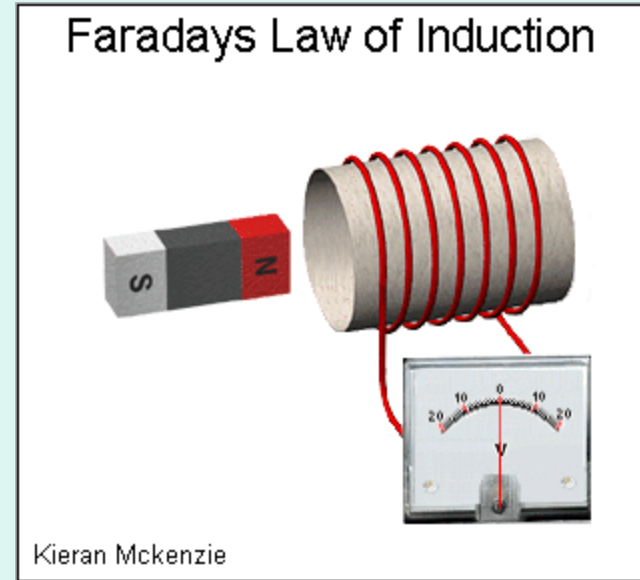
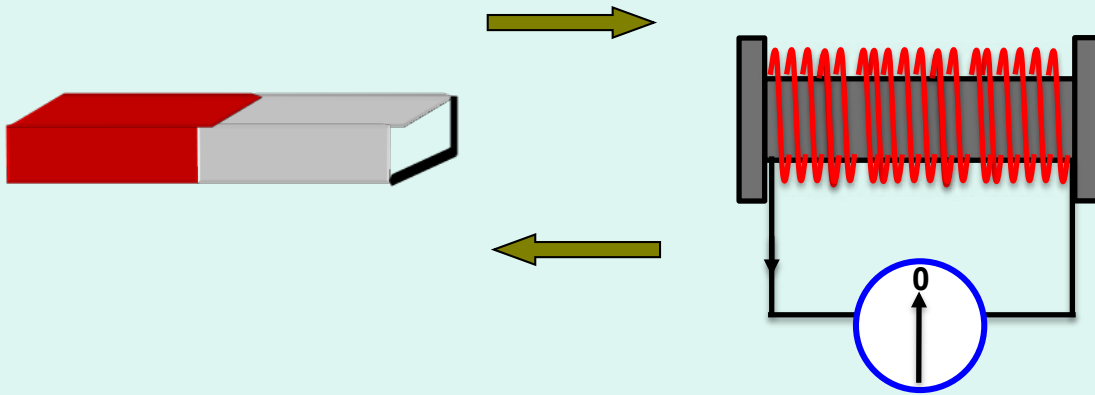

قانون فاراداي swf

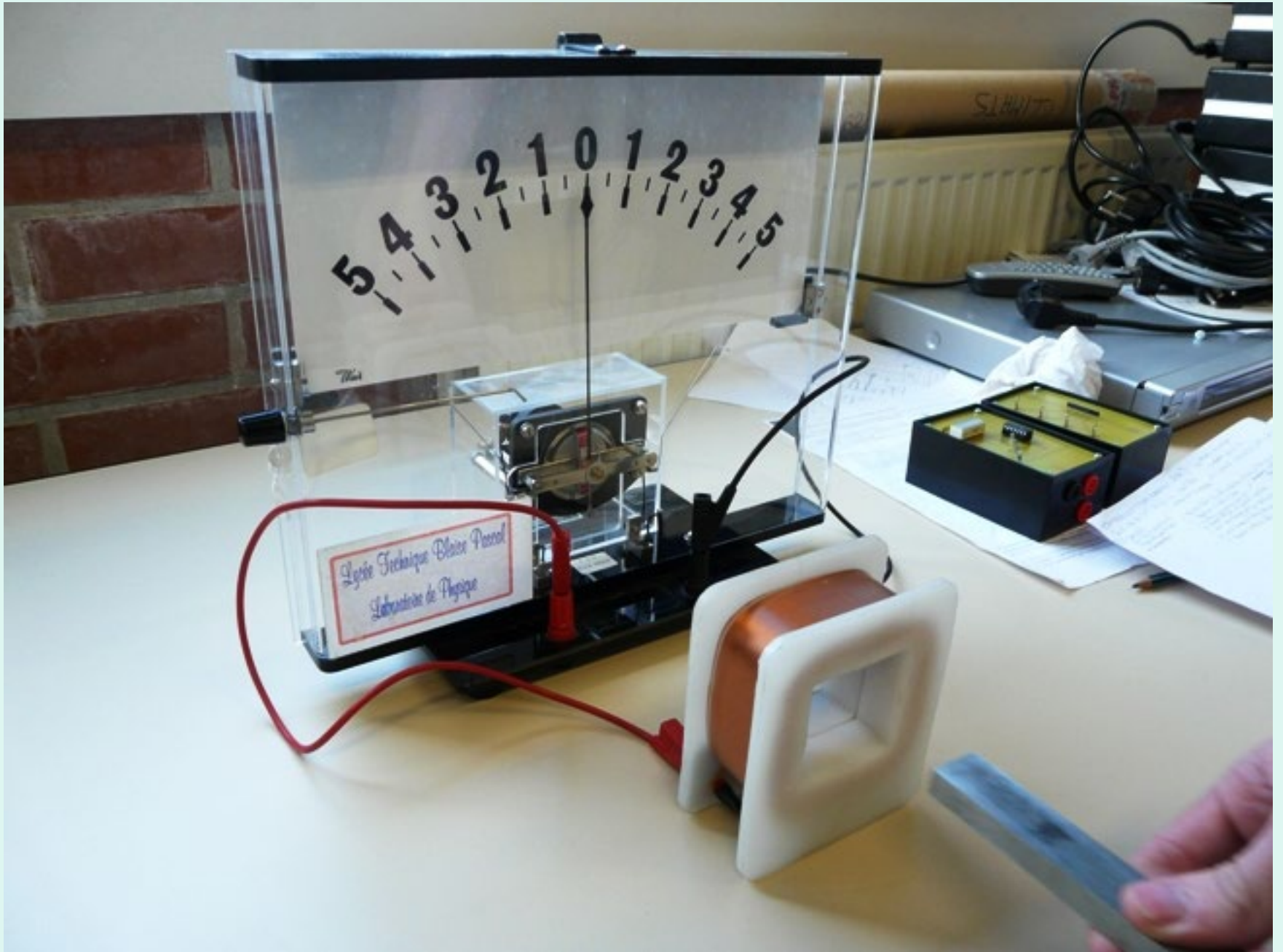

## Roue de barlou



مرحل في دارة الكترونية

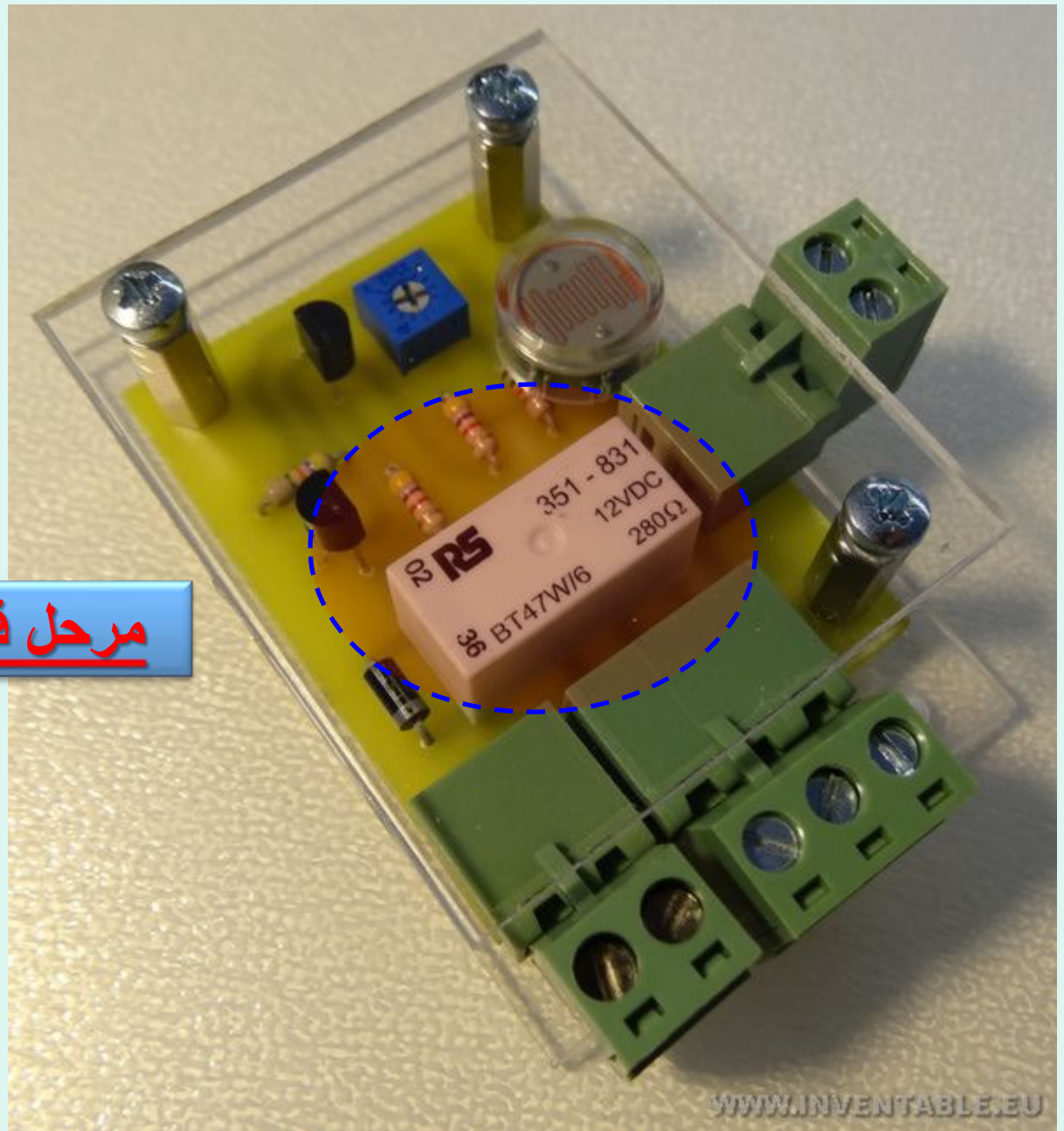

## 8- اختيار المرحل: يتوقف على العوامل التالية:

- 1- توتر التغذية الخاص بالوشيعة 3V , 5V , 6V , 9V , 12V , 24V , .....
- 2 – التوتر الأدنى اللازم لغلق الماسات  $V_{min}$ .
- 3- عدد ونوعية ماسات المرحل.
- 4- قيمة توتر وتيار الذي تتحمله الماسات.
- 5- قيمة مقاومة وشيعة المرحل.
- 6- الاستطاعة المستهلكة من طرف المرحل.



- |                                  |                  |
|----------------------------------|------------------|
| 1. Type                          | : MT2-C93401     |
| 2. Tension de bobine             | : 5VDC           |
| 3. Résistance de la bobine       | : 1680Ω          |
| 4. Puissance                     | : 150mW          |
| 5. Courant de commutation        | : 2A             |
| 6. Configuration de contact      | : DPDT           |
| 7. Voltage de Contact VAC        | : 250V           |
| 8. température de fonctionnement | : -40°C to +85°C |

## Relais SPDT



## Relais DPST



نوعية ماسات المرحل: هناك أربع فئات :

. 1- فئة SPST

. 2- فئة DPST

. 3- فئة SPDT

. 4- فئة DPDT

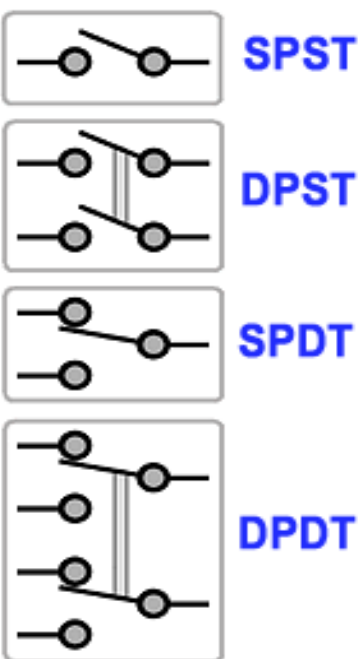

SPST : Single Pole Single Throw.

DPST : Double Pole Single Throw.

SPDT : Single Pole Double Throw.

DPDT : Double Pole Double Throw

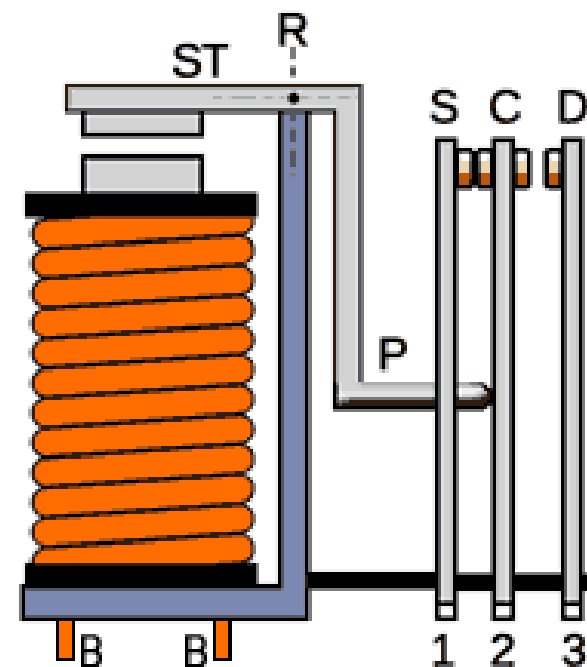

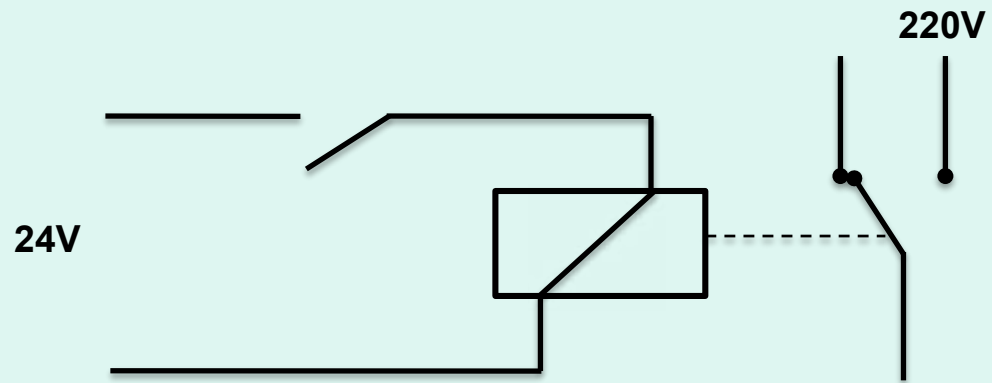

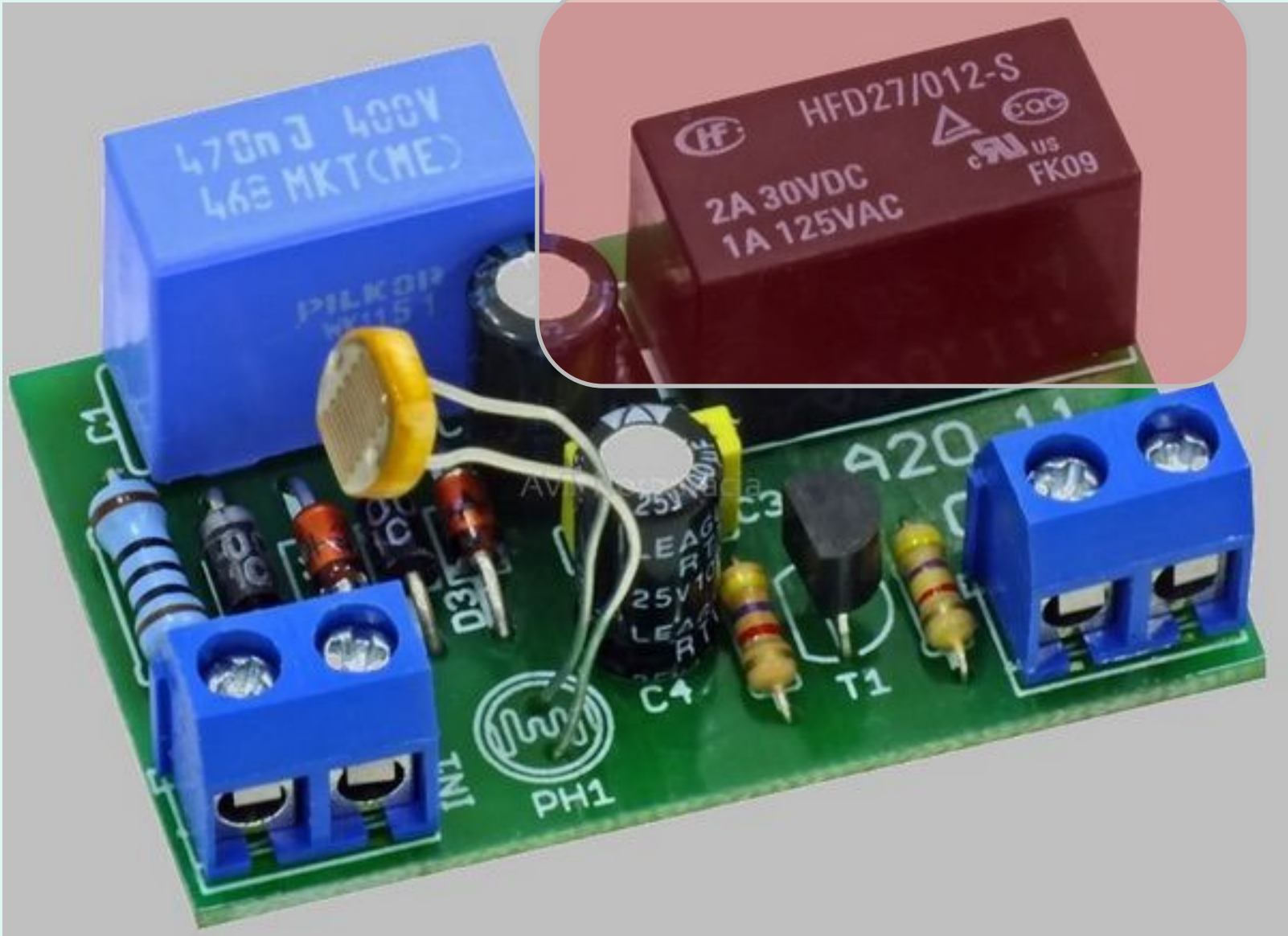

## بعض الأمثلة

المقاومة الوشيعية R	تيار الملمس	الاستطاعة المستهلكة	توتر التغذية	مرجع المرحل Relais
168Ω	2A	150mW	5V	MT2-C93401
720Ω	3A	200mW	12V	V23105-A5303
70Ω	2A	360mW	5V	GS-SH-205D
320Ω	5A	450mW	12V	JZC-32F/012
167Ω	3A	200mW	5V	HFD2/005-S-L2
4170Ω	10A	640mW	48V	G2R1-48V

المقاومة الوشيعية R	تيار الملمس	الاستطاعة المستهلكة	توتر التغذية	مرجع المرحل Relais
168Ω	2A	150mW	5V	MT2-C93401
720Ω	3A	200mW	12V	V23105-A5303
70Ω	2A	360mW	5V	GS-SH-205D
320Ω	5A	450mW	12V	JZC-32F/012
167Ω	3A	200mW	5V	HFD2/005-S-L2
4170Ω	10A	640mW	48V	G2R1-48V

Resistance de la bobine	Courant de contact	Puissance de consommation	Tension d'alimentation	Référence de relais électromécanique
168Ω	2A	150mW	5V	MT2-C93401
720Ω	3A	200mW	12V	V23105-A5303
70Ω	2A	360mW	5V	GS-SH-205D
320Ω	5A	450mW	12V	JZC-32F/012
167Ω	3A	200mW	5V	HFD2/005-S-L2
4170Ω	10A	640mW	48V	G2R1-48V

Resistance de la bobine	Courant de contact	Puissance de consommation	Tension d'alimentation	Référence de relais électromécanique
168Ω	2A	150mW	5V	MT2-C93401
720Ω	3A	200mW	12V	V23105-A5303
70Ω	2A	360mW	5V	GS-SH-205D
320Ω	5A	450mW	12V	JZC-32F/012
167Ω	3A	200mW	5V	HFD2/005-S-L2
4170Ω	10A	640mW	48V	G2R1-48V

**بعض القراءات في بعض المرحلات**

# Product code structure

Typical product code

**C934**

**22**

## Type

**C934** MT2 Series Signal Relay  
2 form C, 2 CO, AgNi +Au contacts

## Coil

Coil code: please refer to coil versions table

# MT2-C93401



## Terminal assignment

TOP view on component side of PCB

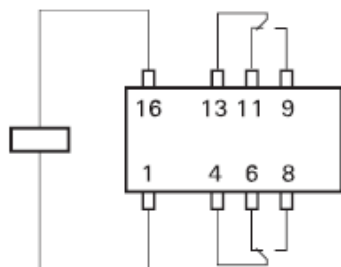

Coil code	Rated voltage VDC	Operate voltage VDC <sub>min.</sub>	Limiting Voltage VDC <sub>max.</sub>	Release voltage VDC <sub>min.</sub>	Coil resistance Ω±10%	Rated coil power mW
<b>High sensitive version, 150mW</b>						
00	3	2.1	8.1	0.3	60	150
07	3.3	2.3	8.8	0.33	72	150
06	4.5	3.2	12.2	0.45	136	150
01	5	3.6	13.5	0.5	168	150
27	6	4.3	16.2	0.6	240	150
05	9	6.4	24.3	0.9	544	150
02	12	8.6	32.4	1.2	968	150
03	24	17.1	64.8	2.4	3872	150
04	48	34.1	129.6	4.8	15468	150
<b>Sensitive version, 200mW</b>						
14	3	2	7	0.3	45	200
15	4.5	2.9	10.5	0.45	101	200
16	5	3.3	11.6	0.5	125	200
28	6	3.9	14	0.6	180	200
17	9	5.9	21	0.9	405	200
18	12	7.8	28	1.2	720	200
19	24	15.6	59.9	2.4	2880	200
20	48	31.2	112	4.8	11520	200
<b>Sensitive version, 300mW</b>						
33	4.5	3.1	8.9	0.45	73	300
34	5	3.4	9.9	0.5	90	300
12	12	8.25	23.6	1.2	515	300
35	24	16.5	47.3	2.4	2060	300
36	48	32.5	54.6	4.8	8240	300
<b>Standard version, 400mW</b>						
21	4.5	2.9	8.9	0.45	50	400
22	5	3.3	9.9	0.5	63	400
29	6	3.9	11.8	0.6	90	400
23	9	5.9	17.7	0.9	203	400
24	12	7.8	23.6	1.2	360	400
25	24	15.6	47.3	2.4	1440	400
26	48	31.2	94.6	4.8	5760	400
<b>Standard version, 550mW</b>						
38	4.5	2.9	6.3	0.45	36	550
50	5	3.3	7	0.5	45	550
37	6	3.9	8.4	0.6	66	550
32	12	7.8	16.8	1.2	280	550
31	24	15.6	33.6	2.4	1050	550
30	48	31.2	67.2	4.8	4100	550

## Product code structure

Typical product code

C934

22

### Type

C934 MT2 Series Signal Relay  
2 form C, 2 CO, AgNi +Au contacts

### Coil

Coil code: please refer to coil versions table



Coil code	Rated voltage VDC	Operate voltage VDC <sub>min.</sub>	Limiting Voltage VDC <sub>max.</sub>	Release voltage VDC <sub>min.</sub>	Coil resistance Ω±10%	Rated coil power mW
<b>High sensitive version, 150mW</b>						
00	3	2.1	8.1	0.3	60	150
07	3.3	2.3	8.8	0.33	72	150
06	4.5	3.2	12.2	0.45	136	150
01	5	3.6	13.5	0.5	168	150
27	6	4.3	16.2	0.6	240	150
05	9	6.4	24.3	0.9	544	150
02	12	8.6	32.4	1.2	968	150
03	24	17.1	64.8	2.4	3872	150
04	48	34.1	129.6	4.8	15468	150

**MT2-C93401**

1. Type : MT2-C93401
2. Tension de bobine : 5VDC
3. Résistance de la bobine : 1680Ω
4. Puissance : 150mW
5. Courant de commutation : 2A
6. température de fonctionnement : -40°C to +85°C

## Product code structure

Typical product code

C934

22

### Type

C934 MT2 Series Signal Relay  
2 form C, 2 CO, AgNi +Au contacts

### Coil

Coil code: please refer to coil versions table



Coil code	Rated voltage VDC	Operate voltage VDC <sub>min.</sub>	Limiting Voltage VDC <sub>max.</sub>	Release voltage VDC <sub>min.</sub>	Coil resistance Ω±10%	Rated coil power mW
<b>Standard version, 400mW</b>						
21	4.5	2.9	8.9	0.45	50	400
22	5	3.3	9.9	0.5	63	400
29	6	3.9	11.8	0.6	90	400
23	9	5.9	17.7	0.9	203	400
24	12	7.8	23.6	1.2	360	400
25	15.6	10.4	31.2	1.6	1440	400
26	48	31.2	94.6	4.8	5760	400

**MT2-C93425**

1. Type : MT2-C93425
2. Tension de bobine : 24VDC
3. Résistance de la bobine : 1440Ω
4. Puissance : 400mW
5. Courant de commutation : 2A
6. température de fonctionnement : -40°C to +85°C

أكمل

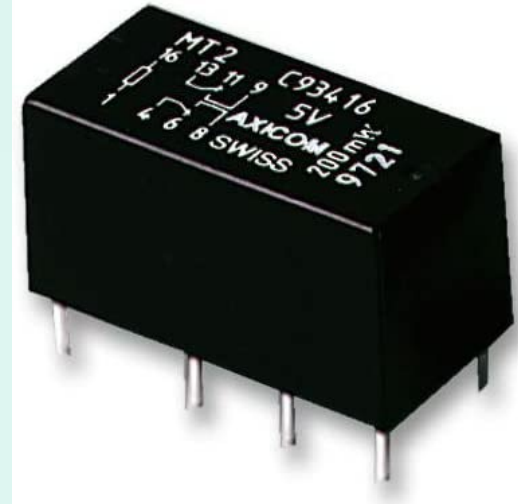

1-type:.....

2-.....

.....

.....

.....

.....

.....

.....

.....

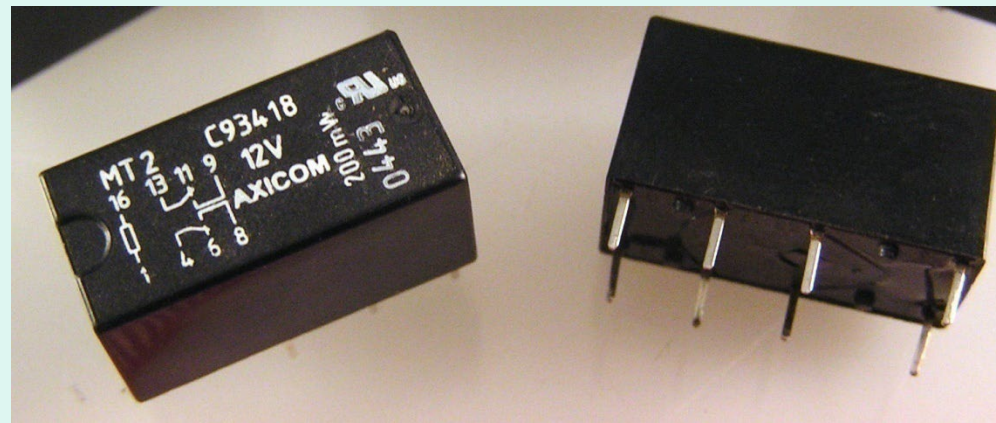

Type	JZC-32F / 012 H S L Q
Coil voltage	3, 5, 6, 9, 12, 18, 24VDC
Contact arrangement	H:1Form A Z:1Form C
Structure	Nil: Unsealed S: Sealed
Coil Power	L: Sensitive Nil: Standard
Contact Capacity	Q: High Capacity Nil: Standard



COIL	
Coil power	Standard:0.45W Sensitive:0.2W

**Standard Type**

Nominal Voltage VDC	Pick-up Voltage VDC	Drop-out Voltage VDC	Max. allowable Voltage VDC(at 20°C)	Coil Resistance Ω
3	2.25	0.15	3.9	20 ± 10%
5	3.75	0.25	6.5	55 ± 10%
6	4.50	0.30	7.8	80 ± 10%
9	6.75	0.45	11.7	180 ± 10%
12	9.00	0.60	15.6	320 ± 10%
18	13.5	0.90	23.4	720 ± 10%
24	18.0	1.20	31.2	1280 ± 10%

**Sensitive Type**

Nominal Voltage VDC	Pick-up Voltage VDC	Drop-out Voltage VDC	Max. allowable Voltage VDC(at 20°C)	Coil Resistance Ω
3	2.25	0.15	4.5	45 ± 10%
5	3.75	0.25	7.5	125 ± 10%
6	4.50	0.30	9.0	180 ± 10%
9	6.75	0.45	13.5	400 ± 10%
12	9.00	0.60	18.0	720 ± 10%
18	13.5	0.90	27.0	1600 ± 10%
24	18.0	1.20	36.0	2800 ± 10%

### Standard Type

Nominal Voltage VDC	Pick-up Voltage VDC	Drop-out Voltage VDC	Max. allowable Voltage VDC(at 20°C)	Coil Resistance $\Omega$
3	2.25	0.15	3.9	20 $\pm$ 10%
5	3.75	0.25	6.5	55 $\pm$ 10%
6	4.50	0.30	7.8	80 $\pm$ 10%
9	6.75	0.45	11.7	180 $\pm$ 10%
12	9.00	0.60	15.6	320 $\pm$ 10%
18	13.5	0.90	23.4	720 $\pm$ 10%
24	18.0	1.20	31.2	1280 $\pm$ 10%

**JZC-32F/012HST**



### Sensitive Type

Nominal Voltage VDC	Pick-up Voltage VDC	Drop-out Voltage VDC	Max. allowable Voltage VDC(at 20°C)	Coil Resistance $\Omega$
3	2.25	0.15	4.5	45 $\pm$ 10%
5	3.75	0.25	7.5	125 $\pm$ 10%
6	4.50	0.30	9.0	180 $\pm$ 10%
9	6.75	0.45	13.5	400 $\pm$ 10%
12	9.00	0.60	18.0	720 $\pm$ 10%
18	13.5	0.90	27.0	1600 $\pm$ 10%
24	18.0	1.20	36.0	2800 $\pm$ 10%

**JZC-32F/012HST**

1. Type **Standard** : JZC-32F/012
2. Tension de bobine : 12 VDC
3. Résistance de la bobine : 320 $\Omega$
4. Courant de la bobine : 38mA
5. Courant de commutation: 5 A
6. Puissance : 450mW

1. Type **Sensitive** : JZC-32F/012
2. Tension de bobine : 12 VDC
3. Résistance de la bobine : 720 $\Omega$
4. Courant de la bobine : 38mA
5. Courant de commutation: 5 A
6. Puissance : 200mW

أكمل



1-type:.....

2-.....

.....

.....

.....

.....

.....

.....

.....

JRC-27F /

012

S

Type

Coil voltage 3, 5, 6, 9, 12, 15, 24, 48VDC(Standard only)

Coil Power S: Sensitive M: Standard

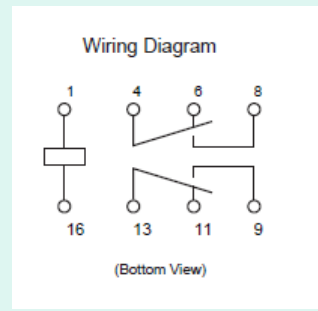

Sensitive (200mW) 20°C

Order Number	Coil Voltage VDC	Pick-up Voltage VDC (Max.)	Drop-out Voltage VDC (Min.)	Coil Resistance $\Omega$ $\pm 10\%$	Allow Voltage VDC (Max.)
003-S	3	2.25	0.3	45	6
005-S	5	3.75	0.5	125	10
006-S	6	4.50	0.6	180	12
009-S	9	6.80	0.9	405	18
012-S	12	9.00	1.2	720	24
015-S	15	11.3	1.5	1125	30
024-S	24	18.0	2.4	2880	48

Standard (360mW) 20°C

Order Number	Coil Voltage VDC	Pick-up Voltage VDC (Max.)	Drop-out Voltage VDC (Min.)	Coil Resistance $\Omega$ $\pm 10\%$	Allow Voltage VDC (Max.)
003-M	3	2.25	0.3	30	4.5
005-M	5	3.75	0.5	90	8.0
006-M	6	4.50	0.6	130	10.0
009-M	9	6.80	0.9	280	14.5
012-M	12	9.00	1.2	450	18.5
015-M	15	11.3	1.5	625	22.0
024-M	24	18.0	2.4	1600	35.5
048-M	48	36.0	4.8	4000	56.0

Sensitive (200mW)

20°C

Order Number	Coil Voltage VDC	Pick-up Voltage VDC (Max.)	Drop-out Voltage VDC (Min.)	Coil Resistance $\Omega$ $\pm 10\%$	Allow Voltage VDC (Max.)
003-S	3	2.25	0.3	45	6
005-S	5	3.75	0.5	125	10
006-S	6	4.50	0.6	180	12
009-S	9	6.80	0.9	405	18
<b>012-S</b>	<b>12</b>	<b>9.00</b>	<b>1.2</b>	<b>720</b>	<b>24</b>
015-S	15	11.3	1.5	1125	30
024-S	24	18.0	2.4	2880	48

JRC-27F/012.S



Standard (360mW)

20°C

Order Number	Coil Voltage VDC	Pick-up Voltage VDC (Max.)	Drop-out Voltage VDC (Min.)	Coil Resistance $\Omega$ $\pm 10\%$	Allow Voltage VDC (Max.)
003-M	3	2.25	0.3	30	4.5
005-M	5	3.75	0.5	90	8.0
006-M	6	4.50	0.6	130	10.0
009-M	9	6.80	0.9	280	14.5
<b>012-M</b>	<b>12</b>	<b>9.00</b>	<b>1.2</b>	<b>450</b>	<b>18.5</b>
015-M	15	11.3	1.5	625	22.0
024-M	24	18.0	2.4	1600	35.5
048-M	48	36.0	4.8	4000	56.0

JRC-27F/012.M

1. Type : JRC-27F/012.S
2. Tension de bobine : 12VDC
3. Résistance de la bobine : 720 $\Omega$
4. Puissance : 200mW
5. Courant de commutation : 2A
6. température de fonctionnement : -40°C to +85°C

1. Type : JRC-27F/012.M
2. Tension de bobine : 12VDC
3. Résistance de la bobine : 450 $\Omega$
4. Puissance : 360mW
5. Courant de commutation : 2A
6. température de fonctionnement : -40°C to +85°C

أكمل



1-type:.....

2-.....

.....

.....

.....

.....

.....

.....

.....

## Product code structure

Typical product code

V23105-A5

001

A201

### Type

V23105-A5 D2n Series Signal Relay

### Coil

Coil code: please refer to coil versions table

0xx 150 mW      4xx 400 mW  
 3xx 200 mW      5xx 550 mW

### Contacts

A201 2 from C, 2 CO, AgNi-Au contacts

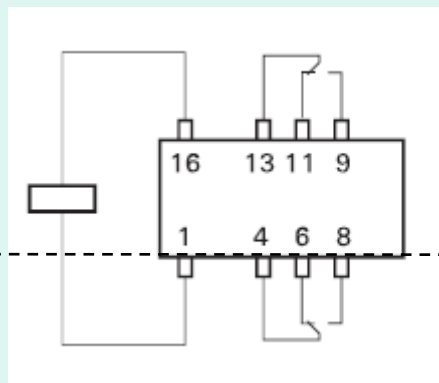

### Coil versions, monostable

Coil code	Rated voltage VDC	Operate voltage VDC <sub>min.</sub>	Limiting Voltage VDC <sub>max.</sub>	Release voltage VDC <sub>min.</sub>	Coil resistance Ω±10%	Rated coil power mW
-----------	-------------------	-------------------------------------	--------------------------------------	-------------------------------------	-----------------------	---------------------

#### 150mW coil power

001	5	4.0	11.7	0.25	167	150
002	6	4.8	14.0	0.30	240	150
006	9	7.2	21.0	0.45	540	150
003	12	9.6	28.0	0.60	960	150
005	24	19.2	56.0	1.20	3840	150

#### 200mW coil power

308	3	2.1	6.1	0.15	45	200
301	5	3.5	10.1	0.25	125	200
302	6	4.2	12.2	0.30	180	200
306	9	6.3	18.2	0.45	405	200
303	12	8.4	24.3	0.60	720	200
305	24	16.8	48.6	1.20	2880	200
307	48	33.6	97.2	2.40	11520	200

#### 400mW coil power

401	5	3.5	7.2	0.25	62	400
402	6	4.2	8.6	0.30	90	400
406	9	6.3	12.9	0.42	203	400
403	12	8.4	17.2	0.60	360	400
405	24	16.8	34.3	1.20	1440	400
407	48	33.6	68.6	2.40	5760	400

#### >500mW coil power

501	5	3.5	6.1	0.25	36	695
502	6	4.2	7.3	0.30	70	515
506	9	6.3	10.9	0.45	140	580
503	12	8.4	14.5	0.60	280	515
505	24	16.8	29.1	1.20	1050	550
507	48	33.6	58.1	2.40	4000	575

## Product code structure

Typical product code

V23105-A5

001

A201

### Type

V23105-A5 D2n Series Signal Relay

### Coil

Coil code: please refer to coil versions table

0xx	150 mW	4xx	400 mW
3xx	200 mW	5xx	550 mW

### Contacts

A201 2 from C, 2 CO, AgNi-Au contacts



V23105-A5303-A201

- Type : Relais V23105-A5303-A201
- Tension de bobine : 12 V cc
- Résistance de la bobine : 720Ω
- Contact Configuration : DPDT
- Type de montage : Montage PCB
- Courant de commutation : 3A
- Type de borne : À travers le trou
- Nombre de pôles : 2
- Puissance de commutation : 200mW
- Longueur : 20,2 mm
- la taille : 11 mm
- Séries : D2n
- Profondeur : 10 mm

### Coil versions, monostable

Coil code	Rated voltage VDC	Operate voltage VDC <sub>min.</sub>	Limiting Voltage VDC <sub>max.</sub>	Release voltage VDC <sub>min.</sub>	Coil resistance Ω±10%	Rated coil power mW
<b>150mW coil power</b>						
001	5	4.0	11.7	0.25	167	150
002	6	4.8	14.0	0.30	240	150
006	9	7.2	21.0	0.45	540	150
003	12	9.6	28.0	0.60	960	150
005	24	19.2	56.0	1.20	3840	150
<b>200mW coil power</b>						
308	3	2.1	6.1	0.15	45	200
301	5	3.5	10.1	0.25	125	200
302	6	4.2	12.2	0.30	180	200
306	9	6.3	18.2	0.45	405	200
303	12	8.4	24.3	0.60	720	200
305	24	16.8	48.6	1.20	2880	200
307	48	33.6	97.2	2.40	11520	200
<b>400mW coil power</b>						
401	5	3.5	7.2	0.25	62	400
402	6	4.2	8.6	0.30	90	400
406	9	6.3	12.9	0.42	203	400
403	12	8.4	17.2	0.60	360	400
405	24	16.8	34.3	1.20	1440	400
407	48	33.6	68.6	2.40	5760	400
<b>&gt;500mW coil power</b>						
501	5	3.5	6.1	0.25	36	695
502	6	4.2	7.3	0.30	70	515
506	9	6.3	10.9	0.45	140	580
503	12	8.4	14.5	0.60	280	515
505	24	16.8	29.1	1.20	1050	550
507	48	33.6	58.1	2.40	4000	575

أكمل

1-type:.....

2-.....

.....

.....

.....

.....

.....

.....

.....

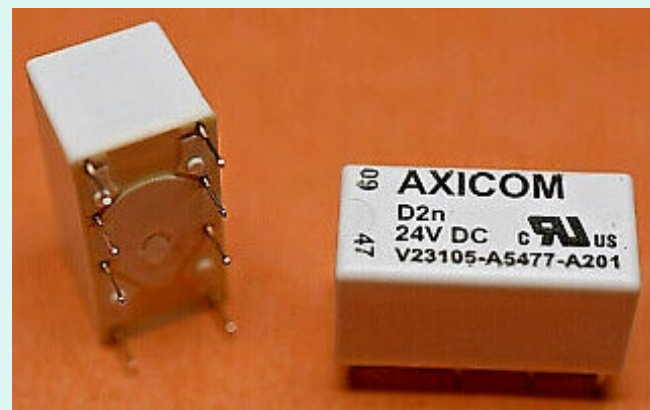

# Product code structure

Typical product code

V23079 A 1 001 B 301

## Type

V23079 Signal Relay P2 Series

## Version

- A** THT, monostable                      **D** SMT, monostable, long term.                      **G** SMT, monostable, short term.
- B** THT, latching, 2 coils                      **E** SMT, latching, 2 coils long term.                      **H** SMT, latching, 2 coils short term.
- C** THT, latching, 1 coil                      **F** SMT, latching, 1 coil long term.                      **J** SMT, latching, 1 coil short term.

## Coil design

- 1** Standard coil (not for high dielectric version)
- 2** Overmolded coil

## Coil

Coil code: please refer to coil versions table

## Version

- B** Standard version
- X** High dielectric version

## Contacts for standard versions

- 301** 2 form C contacts (2 CO), AgNi +Au
- 201** 2 form C contacts (2 CO), AgPd +Au; on request only

## Coil Data (continued)

### Coil versions **bistable**

Coil code	Rated voltage VDC	Set voltage VDC	Limiting voltage VDC	Reset voltage VDC	Coil resistance $\Omega \pm 10\%$	Rated coil power mW
<b>Bistable, 1 coil</b>						
108	3.00	2.25	9.2	-2.25	128	70
111	4.50	3.38	13.85	-3.38	289	70
101	5.00	3.75	15.33	-3.75	357	70
102	6.00	4.50	18.5	-4.50	514	70
106	9.00	6.75	27.75	-6.75	1157	70
103	12.00	9.00	37	-9.00	2057	70
105	24.00	18.00	74	-18.00	8228	70

### Coil versions **bistable, 2 coil**

219	2.00	1.50	4.33	1.50	28	140
218	2.40	1.80	5.2	1.80	41	140
208	3.00	2.25	6.5	2.25	64	140
211	4.50	3.38	9.8	3.38	145	140
201	5.00	3.75	10.9	3.75	178	140
202	6.00	4.50	13	4.50	257	140
206	9.00	6.75	19.6	6.75	578	140
203	12.00	9.00	26.15	9.00	1029	140
205	24.00	18.00	52.3	18.00	4114	140

## Coil Data

Magnetic system	polarized
Coil voltage range	2 to 24VDC
Max. coil temperature	125°C
Thermal resistance	< 125K/W

### Coil versions **monostable**

Coil code	Rated voltage VDC	Operate voltage VDC	Limiting Voltage VDC	Release voltage VDC	Coil resistance $\Omega \pm 10\%$	Rated coil power mW
008	3.00	2.25	6.50	0.30	64	140
016	4.00	3.00	8.70	0.40	114	140
011	4.50	3.38	9.80	0.45	145	140
001	5.00	3.75	10.90	0.50	178	140
002	6.00	4.50	13.00	0.60	257	140
006	9.00	6.75	19.60	0.90	578	140
003	12.00	9.00	26.15	1.20	1029	140
005	24.00	18.00	52.30	2.40	4114	140

All figures are given for coil without pre-energization, at ambient temperature +23°C. Other coil voltages on request.

All figures are given for coil without pre-energization, at ambient temperature +23°C. Other coil voltages on request.

## Product code structure

Typical product code

**V23079** A 1 **001** B 301

### Type

**V23079** Signal Relay P2 Series

### Version

<b>A</b> THT, monostable	<b>D</b> SMT, monostable, long term.	<b>G</b> SMT, monostable, short term.
<b>B</b> THT, latching, 2 coils	<b>E</b> SMT, latching, 2 coils long term.	<b>H</b> SMT, latching, 2 coils short term.
<b>C</b> THT, latching, 1 coil	<b>F</b> SMT, latching, 1 coil long term.	<b>J</b> SMT, latching, 1 coil short term.

### Coil design

**1** Standard coil (not for high dielectric version)  
**2** Overmolded coil

### Coil

Coil code: please refer to coil versions table

### Version

**B** Standard version  
**X** High dielectric version

### Contacts for standard versions

**301** 2 form C contacts (2 CO), AgNi +Au  
**201** 2 form C contacts (2 CO), AgPd +Au; on request only



**V23079-D1005-B301**

1. Type :Relais monostable standard
2. Tension de bobine : 24VDC
3. Matériau du contact : AgNi+Au
4. Résistance de la bobine : 4114Ω
5. Puissance de consommation : 140mW

## Coil Data

Magnetic system	polarized
Coil voltage range	2 to 24VDC
Max. coil temperature	125°C
Thermal resistance	< 125K/W

## Coil versions, monostable

Coil code	Rated voltage VDC	Operate voltage VDC	Limiting Voltage VDC	Release voltage VDC	Coil resistance Ω±10%	Rated coil power mW
008	3.00	2.25	6.50	0.30	64	140
016	4.00	3.00	8.70	0.40	114	140
011	4.50	3.38	9.80	0.45	145	140
001	5.00	3.75	10.90	0.50	178	140
002	6.00	4.50	13.00	0.60	257	140
006	9.00	6.75	19.60	0.90	578	140
003	12.00	9.00	26.15	1.20	1029	140
<b>005</b>	<b>24.00</b>	<b>18.00</b>	<b>52.30</b>	<b>2.40</b>	<b>4114</b>	<b>140</b>

All figures are given for coil without pre-energization, at ambient temperature +23°C.  
 Other coil voltages on request.

# أكمل

1. ....
2. ....
3. ....
4. ....
5. ....



أكمل



1. ....
2. ....
3. ....
4. ....
5. ....

1 form C contact (1 CO)

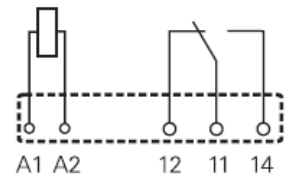

S0258-AB

1 form A contact (1 NO)

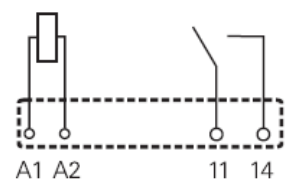

S0258-AC

<input type="checkbox"/>	Type de bobine	DC
<input type="checkbox"/>	Configuration de contact	2CO
<input type="checkbox"/>	Type de terminaison	Broche PC
<input type="checkbox"/>	Type de relais	Monostable
<input type="checkbox"/>	Résistance de la bobine	1.03 kOhm
<input type="checkbox"/>	Tension de la bobine	12 V
<input type="checkbox"/>	Largeur	7.2 mm
<input type="checkbox"/>	Série	P2
<input type="checkbox"/>	Longueur	14.5 mm
<input type="checkbox"/>	Puissance de commutation	60 W 62.5 VA
<input type="checkbox"/>	Hauteur	9.8 mm
<input type="checkbox"/>	Tension de commutation - CC	220 V
<input type="checkbox"/>	Courant de coupure	2 A
<input type="checkbox"/>	Tension de commutation - CA	250 V



Monostable version

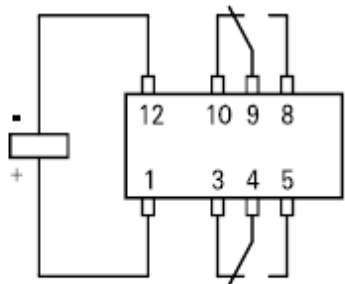

ECR0912-C

Bistable version, 1-coil

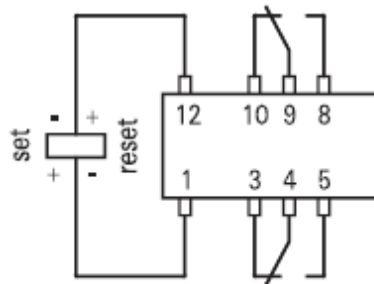

ECR0912-C

Bistable version, 2-coils

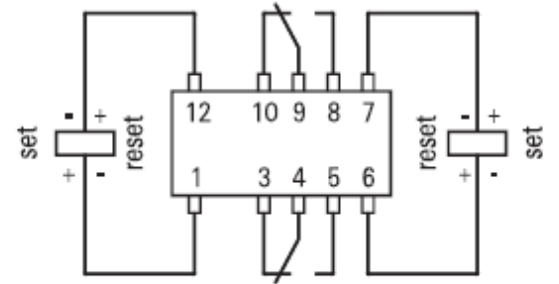

ECR0913-K

## Product code structure

Typical product code **V23092** **-A** **1** **005** **-A** **3** **01**

<b>Type</b>	<b>V23092</b> Slimline PCB relay SNR	
<b>Version</b>	<b>A</b> PCB, vertical version	<b>B</b> PCB, flat pack version
	<b>S</b> Plug-in, vertical version	
<b>Version</b>	<b>1</b> Wash tight	
<b>Coil</b>	Coil code: please refer to coil versions table	
<b>Contact system</b>	<b>A</b> Standard	
<b>Contact material</b>	<b>2</b> AgSnO <sub>2</sub> , gold plated	<b>3</b> AgSnO <sub>2</sub>
	<b>8</b> AgNi 90/10	
<b>Contact configuration</b>	<b>01</b> 1 form C contact (1 CO)	<b>02</b> 1 form A contact (1 NO)

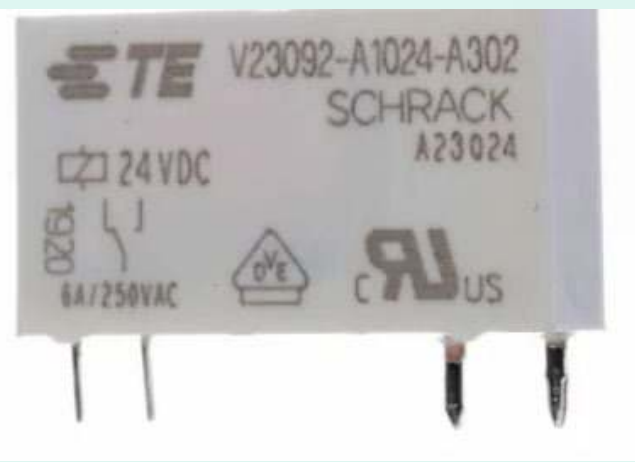

### Coil Data

Coil voltage range	5 to 60VDC
Operative range, IEC 61810	2

### Coil versions, DC coil

Coil code	Rated voltage VDC	Operate voltage VDC	Release voltage VDC	Coil resistance Ω±10% <sup>1)</sup>	Rated coil power mW
005	5	3.5	0.25	147	170
012	12	8.4	0.6	848	170
024	24	16.8	1.2	3390	170
048	48	33.6	2.4	10600 <sup>1)</sup>	217
060	60	42.0	3.0	20500 <sup>1)</sup>	176

**V23092-D1005-B301**

## Product code structure

Typical product code

V23092

-A

1

005

-A

3

01

### Type

V23092 Slimline PCB relay SNR

### Version

**A** PCB, vertical version                      **B** PCB, flat pack version  
**S** Plug-in, vertical version

### Version

**1** Wash tight

### Coil

Coil code: please refer to coil versions table

### Contact system

**A** Standard

### Contact material

**2** AgSnO<sub>2</sub>, gold plated                      **3** AgSnO<sub>2</sub>  
**8** AgNi 90/10

### Contact configuration

**01** 1 form C contact (1 CO)                      **02** 1 form A contact (1 NO)

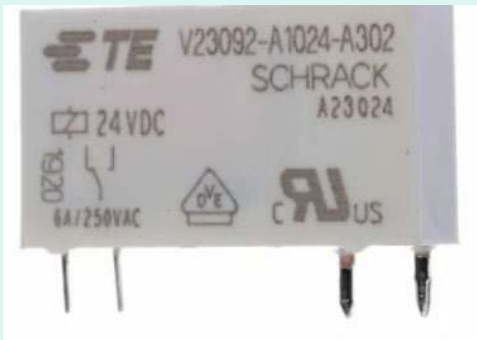

## V23092-A1024-A301

1. Type : Standard
2. Tension de bobine : 24VDC
3. Résistance de la bobine : 3.39KΩ
4. Configuration de Contact : 1NO
5. Type de montage : Montage PCB
6. Courant de commutation : 6A
7. Voltage de Contact : 250V
8. Matériel de contact : AgSnO<sub>2</sub>

## Coil Data

Coil voltage range 5 to 60VDC

Operative range, IEC 61810 2

## Coil versions, DC coil

Coil code	Rated voltage VDC	Operate voltage VDC	Release voltage VDC	Coil resistance Ω±10% <sup>1)</sup>	Rated coil power mW
005	5	3.5	0.25	147	170
012	12	8.4	0.6	848	170
024	24	16.8	1.2	3390	170
048	48	33.6	2.4	10600 <sup>1)</sup>	217
060	60	42.0	3.0	20500 <sup>1)</sup>	176

1-type:.....

2-.....

.....

.....

.....

.....

.....

.....

.....



# Ordering code

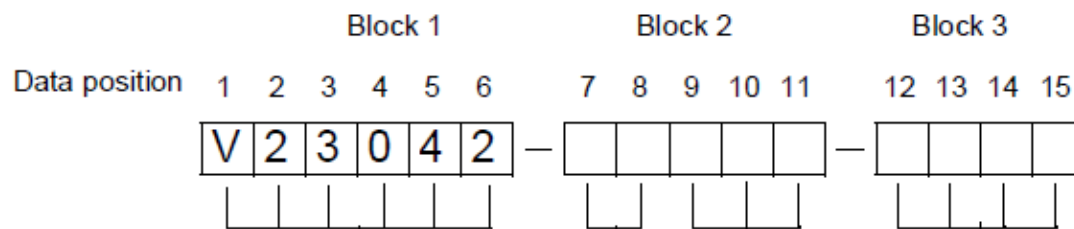

Identification of the small relay, D2

Relay type

- A2 = monostable, 1 winding, pull-in at plus potential on pin 1
- A3 = monostable, 1 winding, pin 16
- B2 = bistable, 2 windings, pin 1 or pin 15
- C2 = bistable, 1 winding, pin 1
- C3 = bistable, 1 winding, pin 16

Coil number

## Monostable, 150 mW

nominal power consumption  
601 = 5 V nominal  
603 = 12 V energizing voltage  
605 = 24 V

## Monostable, 250 mW

nominal power consumption  
008 = 3 V nominal  
001 = 5 V energizing voltage  
003 = 12 V  
005 = 24 V  
015 = 48 V

## Bistable, 2 windings, 200 mW

nominal power consumption  
208 = 3 V nominal  
201 = 5 V energizing voltage  
203 = 12 V  
205 = 24 V

## Bistable, 1 winding, 100 mW

nominal power consumption  
108 = 3 V nominal  
101 = 5 V energizing voltage  
103 = 12 V  
105 = 24 V

## Monostable, 200 mW

nominal power consumption  
308 = 3 V nominal  
301 = 5 V energizing voltage  
303 = 12 V  
305 = 24 V  
307 = 48 V

## Bistable, 2 windings, 150 mW

nominal power consumption  
358 = 3 V nominal  
351 = 5 V energizing voltage  
353 = 12 V  
355 = 24 V

## Bistable, 1 winding, 75 mW

nominal power consumption  
158 = 3 V nominal  
151 = 5 V energizing voltage  
153 = 12 V  
155 = 24 V

Contact assembly / material

# Ordering code

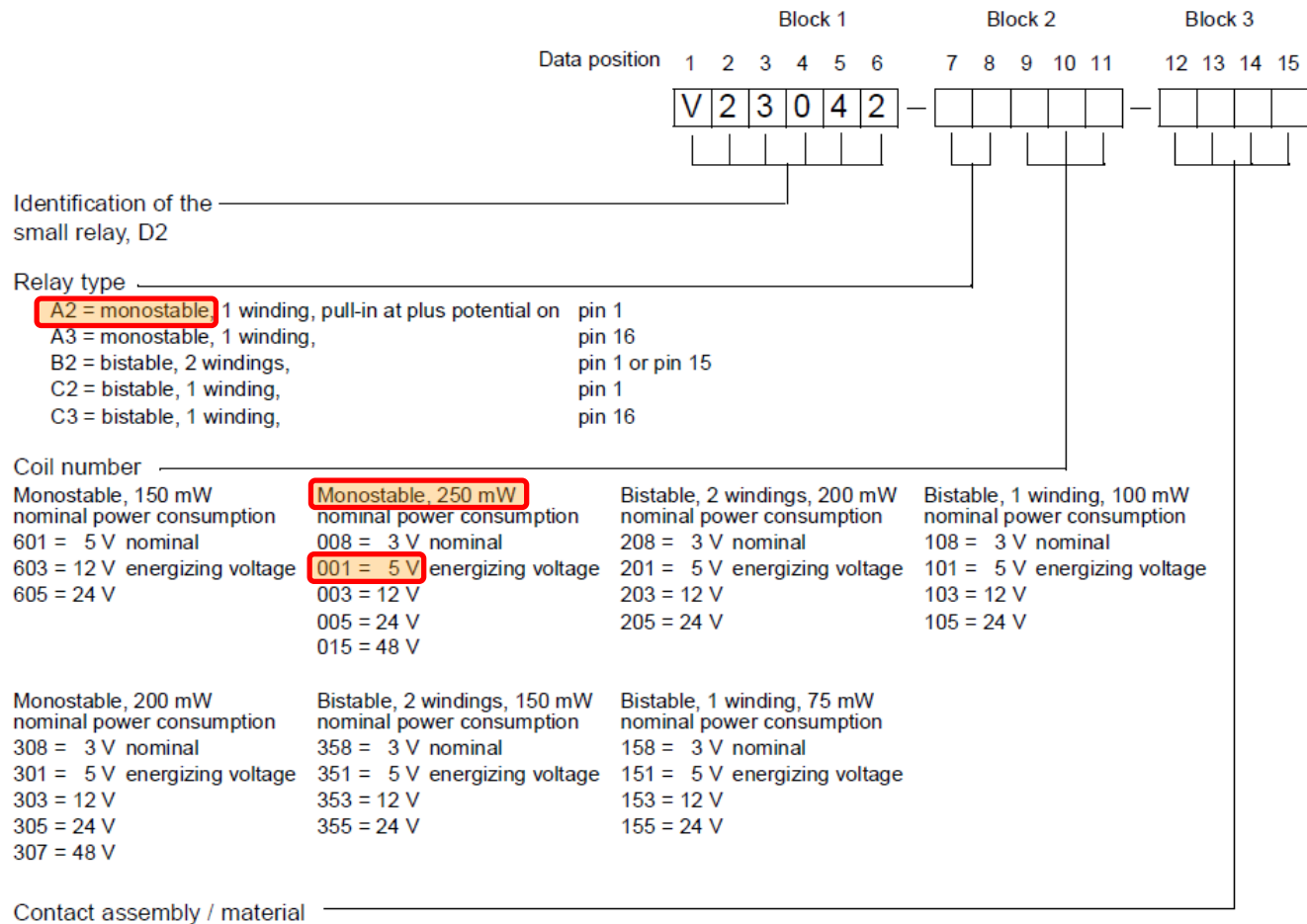

أكمل

1-type:.....

2-.....

.....

.....

.....

.....

.....

.....

.....



# ORDERING INFORMATION

GS - SH - 2 12 D

Coil Sensitivity:

D: Standard DC

T: Medium DC

L: High DC

Coil Voltage: 03: 3V, 05: 5V, 06: 6V, 09: 9V, 12: 12V, 24: 24V, 48: 48V

Number of Pole:

2: Two Poles

Type of Sealing:

SH: RT III Wash Tight

Type:

GS

Coil Sensitivity	Nominal Voltage (VDC)	Nominal Current (mA)	Coil Resistance ( $\Omega \pm 10\%$ )	Power Consumption (W)
GS - D	3	120	25	Abt. 0.36
	5	71.4	70	
	6	60.0	100	
	9	40.0	225	
	12	30.0	400	
	24	15.0	1,600	
	48	7.5	6400	
GS - T	3	66.7	45	Abt. 0.20
	5	40.0	125	
	6	33.3	180	
	9	22.2	405	
	12	16.7	720	
	24	8.3	2,880	
GS - L	3	50.0	60	Abt. 0.15
	5	30.0	167	
	6	25.0	240	
	9	16.7	540	
	12	12.5	960	
	24	6.25	3840	

# ORDERING INFORMATION

GS - SH - 2 12 D

Coil Sensitivity:

D: Standard DC

T: Medium DC

L: High DC

Coil Voltage: 03: 3V, 05: 5V, 06: 6V, 09: 9V, 12: 12V, 24: 24V, 48: 48V

Number of Pole:

2: Two Poles

Type of Sealing:

SH: RT III Wash Tight

Type:

GS



GS-SH-205D

1. Type : Standard
2. Tension de bobine : 5VDC
3. Résistance de la bobine : 70Ω
4. Puissance de consommation : 360mW
5. Courant nominale : 70mA
6. Nombre de pole : 2 pôles

Coil Sensitivity	Nominal Voltage (VDC)	Nominal Current (mA)	Coil Resistance (Ω±10%)	Power Consumption (W)
GS - D	3	120	25	Abt. 0.36
	5	71.4	70	
	6	60.0	100	
	9	40.0	225	
	12	30.0	400	
	24	15.0	1,600	
GS - T	48	7.5	6400	Abt. 0.20
	3	66.7	45	
	5	40.0	125	
	6	33.3	180	
	9	22.2	405	
	12	16.7	720	
GS - L	24	8.3	2,880	Abt. 0.15
	3	50.0	60	
	5	30.0	167	
	6	25.0	240	
	9	16.7	540	
	12	12.5	960	
	24	6.25	3840	

أكمل

1. ....
2. ....
3. ....
4. ....
5. ....

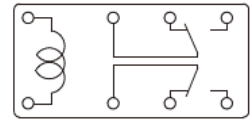
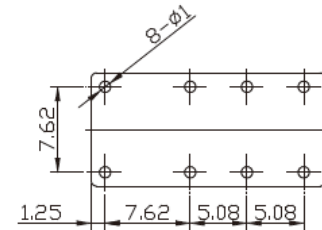

P.C.B Layout  
Bottom View

Bottom View

## ORDERING INFORMATION

HFD2 / 012 -S -L2 -D (XXX)

Type

Coil voltage 3, 5, 6, 9, 12, 15, 24, 48VDC<sup>1)</sup>

Coil power M: Standard S: Sensitive

Sort L1: 1 coil latching L2: 2 coils latching Nil: Single side stable

Contact material D: Ag+Gold plated/Ag+Gold plated A: AgPd/AgPd+Gold plated  
 Nil: AgPd/Ag+Gold plated

Special code<sup>2)</sup> XXX: Customer special requirement Nil: Standard

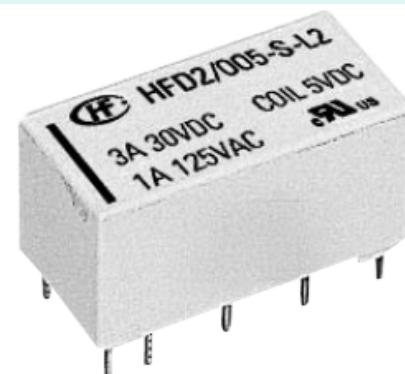

Notes: 1) 48VDC coil voltage is only for single side stable & standard type.

2) The customer special requirement express as special code after evaluating by Hongfa.

## COIL DATA

at 23°C

Single side stable Standard type

Coil Code	Nominal Voltage VDC	Pick-up Voltage VDC max.	Drop-out Voltage VDC min.	Coil Resistance x(1±10%) Ω	Max. Voltage VDC
003-M	3	2.30	0.3	45	6
005-M	5	3.75	0.5	125	10
006-M	6	4.50	0.6	180	12
009-M	9	6.75	0.9	405	18
012-M	12	9.00	1.2	720	24
015-M	15	11.25	1.5	1125	30
024-M	24	18.0	2.4	2880	48
048-M	48	36.0	4.8	11520	96

## COIL DATA

Single side stable Sensitive type

Coil Code	Nominal Voltage VDC	Pick-up Voltage VDC max.	Drop-out Voltage VDC min.	Coil Resistance x(1±10%) Ω	Max. Voltage VDC
005-S	5	4.0	0.5	167	11.5
006-S	6	4.8	0.6	240	13.8
009-S	9	7.2	0.9	540	20.8
012-S	12	9.6	1.2	960	27.7
015-S	15	12.0	1.5	1500	34.6
024-S	24	19.2	2.4	3840	55.4

**1 coil latching Sensitive type**

Coil Code	Nominal Voltage VDC	Set / Reset Voltage VDC max.	Coil Resistance $\times(1\pm 10\%)$ $\Omega$	Max. Voltage VDC
003-S-L1	3	2.4	60	6.9
005-S-L1	5	4.0	330	16
006-S-L1	6	4.8	480	19
009-S-L1	9	7.2	1080	29
012-S-L1	12	9.6	1920	39
015-S-L1	15	12.0	3000	43
024-S-L1	24	19.2	7680	78

**1 coil latching Standard type**

Coil Code	Nominal Voltage VDC	Set / Reset Voltage VDC max.	Coil Resistance $\times(1\pm 10\%)$ $\Omega$	Max. Voltage VDC
003-M-L1	3	2.25	90	8.4
005-M-L1	5	3.75	250	14
006-M-L1	6	4.5	360	17
009-M-L1	9	6.75	810	25
012-M-L1	12	9.0	1440	34
015-M-L1	15	11.25	2220	42
024-M-L1	24	18.0	4000	56

**2 coils latching Sensitive type**

Coil Code	Nominal Voltage VDC	Set / Reset Voltage VDC max.	Coil Resistance $\times(1\pm 10\%)$ $\Omega$	Max. Voltage VDC
003-S-L2	3	2.4	60	6.9
005-S-L2	5	4.0	167	11.5
006-S-L2	6	4.8	240	13.8
009-S-L2	9	7.2	540	20.8
012-S-L2	12	9.6	960	27.7
015-S-L2	15	12.0	1500	34.6
024-S-L2	24	19.2	3840	55.4

**2 coils latching Standard type**

Coil Code	Nominal Voltage VDC	Set / Reset Voltage VDC max.	Coil Resistance $\times(1\pm 10\%)$ $\Omega$	Max. Voltage VDC
003-M-L2	3	2.25	45	6
005-M-L2	5	3.75	125	10
006-M-L2	6	4.5	180	12
009-M-L2	9	6.75	405	18
012-M-L2	12	9.0	720	24
015-M-L2	15	11.25	1125	30
024-M-L2	24	18.0	2040	48

HFD2 / 012 -S -L2 -D

Type

Coil voltage 3, 5, 6, 9, 12, 15, 24, 48VDC <sup>1)</sup>

Coil power M: Standard S: Sensitive

Sort L1: 1 coil latching L2: 2 coils latching Nil: Single side stable

Contact material D: Ag+Gold plated/Ag+Gold plated A: AgPd/AgPd+Gold plated  
 Nil: AgPd/Ag+Gold plated

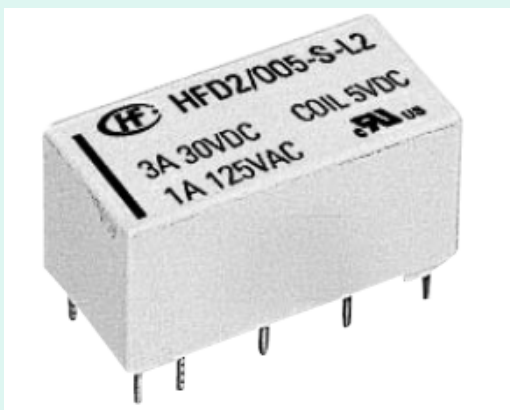

HFD2/005-S-L2

2 coils latching Sensitive type

Coil Code	Nominal Voltage VDC	Set / Reset Voltage VDC max.	Coil Resistance x(1±10%) Ω	Max. Voltage VDC
003-S-L2	3	2.4	60	6.9
005-S-L2	5	4.0	167	11.5
006-S-L2	6	4.8	240	13.8
009-S-L2	9	7.2	540	20.8
012-S-L2	12	9.6	960	27.7
015-S-L2	15	12.0	1500	34.6
024-S-L2	24	19.2	3840	55.4

1. Type : Sensitive
2. Tension de bobine : 5VDC
3. Résistance de la bobine : 167Ω
4. Courant nominale : 3A
5. Voltage de Contact VAC : 1A 125VAC
6. Voltage de Contact VDC : 3A 30VDV

أكمل

1-type:.....

2-.....

.....

.....

.....

.....

.....

.....

.....

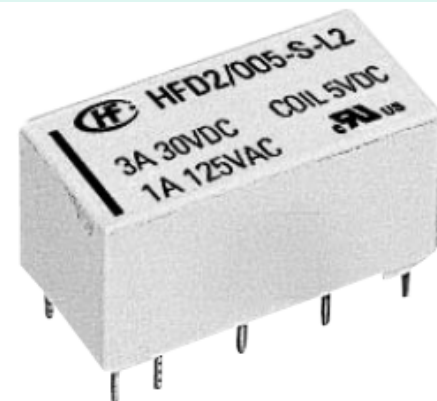

## ORDERING INFORMATION

HF8  
HF8A

-1C

H

12

-D

S

E

F

(XXX)

**Type** HF8: Standard type  
HF8A: Low cost type

**Contact arrangement:** 1A: 1 Form A  
1C: 1 Form C

**Contact capacity** H: Medium Duty (6A)  
Nil: General Duty (3A/2A)

**Coil voltage** 3, 5, 6, 9, 12, 18, 24, 48VDC

**Coil voltage form** D: DC

**Coil power** S: Sensitive Nil: Standard

**Construction**<sup>1)</sup> E: Plastic sealed Nil: Flux proofed

**Insulation standard** F: Class F A: Class A (VDE version, Only for HF8-1AH/1CH)  
Nil: Class B

**Special code**<sup>3)</sup> XXX: Customer special requirement Nil: Standard

## COIL

Coil power

Standard: Approx. 450mW  
(48VDC: Approx. 600mW)

Sensitive: Approx. 330mW

## Sensitive type

Nominal Voltage VDC	Pick-up Voltage VDC max.	Drop-out Voltage VDC min.	Max. Voltage VDC *	Coil Resistance Ω
3	2.25	0.15	3.90	28 x (1±10%)
5	3.75	0.25	6.50	80 x (1±10%)
6	4.50	0.30	7.80	110 x (1±10%)
9	6.75	0.45	11.7	250 x (1±10%)
12	9.00	0.60	15.6	440 x (1±10%)
18	13.5	0.90	23.4	1000 x (1±10%)
24	18.0	1.20	31.2	1780 x (1±10%)
48	36.0	2.40	62.4	7120 x (1±10%)

## Standard type

Nominal Voltage VDC	Pick-up Voltage VDC max.	Drop-out Voltage VDC min.	Max. Voltage VDC *	Coil Resistance Ω
3	2.25	0.15	3.90	20 x (1±10%)
5	3.75	0.25	6.50	56 x (1±10%)
6	4.50	0.30	7.80	80 x (1±10%)
9	6.75	0.45	11.7	180 x (1±10%)
12	9.00	0.60	15.6	320 x (1±10%)
18	13.5	0.90	23.4	720 x (1±10%)
24	18.0	1.20	31.2	1280 x (1±10%)
48	36.0	2.40	62.4	3800 x (1±10%)

ORDERING INFORMATION	
Type	HF8: Standard type HF8A: Low cost type
Contact arrangement:	1A: 1 Form A 1C: 1 Form C
Contact capacity	H: Medium Duty (6A) Nil: General Duty (3A/2A)
Coil voltage	3, 5, 6, 9, 12, 18, 24, 48VDC
Coil voltage form	D: DC
Coil power	S: Sensitive Nil: Standard
Construction <sup>1)</sup>	E: Plastic sealed Nil: Flux proofed
Insulation standard	F: Class F A: Class A (VDE version, Only for HF8-1AH/1CH) Nil: Class B
Special code <sup>3)</sup>	XXX: Customer special requirement Nil: Standard

COIL	
Coil power	Standard: Approx. 450mW (48VDC: Approx. 600mW) Sensitive: Approx. 330mW



## HF8-1CH-12D

1. Type : Sensitive
2. Tension de bobine : 12VDC
3. Résistance de la bobine : 440Ω
4. Puissance de consommation : 330mW
5. Courant de commutation : 6A
6. Voltage Contact VAC : 300VAC

### Sensitive type

Nominal Voltage VDC	Pick-up Voltage VDC max.	Drop-out Voltage VDC min.	Max. Voltage VDC *	Coil Resistance Ω
3	2.25	0.15	3.90	28 x (1±10%)
5	3.75	0.25	6.50	80 x (1±10%)
6	4.50	0.30	7.80	110 x (1±10%)
9	6.75	0.45	11.7	250 x (1±10%)
12	9.00	0.60	15.6	440 x (1±10%)
18	13.5	0.90	23.4	1000 x (1±10%)
24	18.0	1.20	31.2	1780 x (1±10%)
48	36.0	2.40	62.4	7120 x (1±10%)

أكمل

1-type:.....

2-.....

.....

.....

.....

.....

.....

.....

.....



**Product code structure**

Typical product code

**RE****0****3****2****012****Type****RE** Miniature PCB Relay RE**Version****0** Wash tight**Contact Configuration****A** form A (NO) contact**Contact material****1** AgNi 0.15**2** AgNi 0.15 gold plated**5** AgNi 90/10 gold plated**4** AgNi 90/10**0** AgCdO**6** AgCdO gold plated**Coil**

Coil code: please refer to coil versions table



# RE032012

1. Type : Miniature PCB Relay RE
2. Tension de bobine : 12VDC
3. Résistance de la bobine : 720Ω
4. Matériel de contact: AgNiO.15 gold plated
5. Type de contact : NO
6. Courant de commutation : 2A
7. Voltage Contact VAC : 250V
8. Voltage Contact VDC : 220V

**Coil Data**

Coil voltage range 5 to 48 VDC

Operative range, IEC 61810 2

Coil insulation system according UL1446 F

**Coil versions, DC coil**

Coil code	Rated voltage VDC	Operate voltage VDC	Release voltage VDC	Coil resistance Ω±10% <sup>1)</sup>	Rated coil power mW
5	5	3.5	0.5	125	200
6	6	4.2	0.6	180	200
12	12	8.4	1.2	720	200
18	18	12.6	1.8	1620	200
24	24	16.8	2.4	2880 <sup>1)</sup>	200
48	48	33.6	4.8	11520 <sup>1)</sup>	200

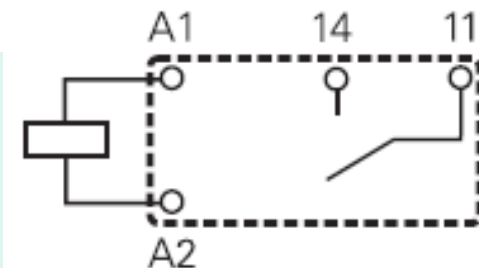
**Miniature PCB Relay RE****SCHRACK**

## Relais électromécanique (EMR)

Exemple: série 34, relais électromécanique, 1 inverseur - 6 A, tension bobine 24 V DC sensible.

3 4 . 5 1 . 7 . 0 2 4 . 0 0 1 0

A B C D

Série \_\_\_\_\_  
Type \_\_\_\_\_  
5 = Relais électromécanique  
Nb. des contacts \_\_\_\_\_  
1 = 1 inverseur, 6 A  
Version bobine \_\_\_\_\_  
7 = DC sensible  
Tension nominale bobine \_\_\_\_\_  
Voir caractéristiques de la bobine

**A: Matériaux contacts**  
0 = Standard AgNi  
4 = AgSnO<sub>2</sub>  
5 = AgNi + Au (5 µm)  
**B: Circuit contacts**  
0 = Inverseur  
3 = NO

**D: Versions spéciales**  
0 = Etanche aux remontées de flux (RT II)  
9 = Version horizontale relais plat  
**C: Variantes**  
1 = Aucune

### Données version DC

Tension nominale $U_N$ V	Code bobine	Plage de fonctionnement		Résistance R Ω	I nominale absorbée à $U_N$ mA
		$U_{min}$ V	$U_{max}$ V		
5	7.005	3.5	7.5	130	38.4
12	7.012	8.4	18	840	14.2
24	7.024	16.8	36	3350	7.1
48	7.048	33.6	72	12300	3.9
60	7.060	42	90	19700	3

## Relais électromécanique (EMR)

Exemple: série 34, relais électromécanique, 1 inverseur - 6 A, tension bobine 24 V DC sensible.

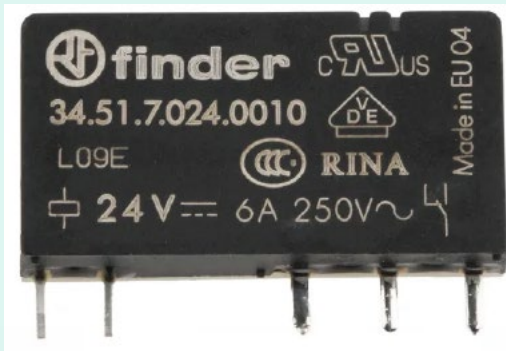
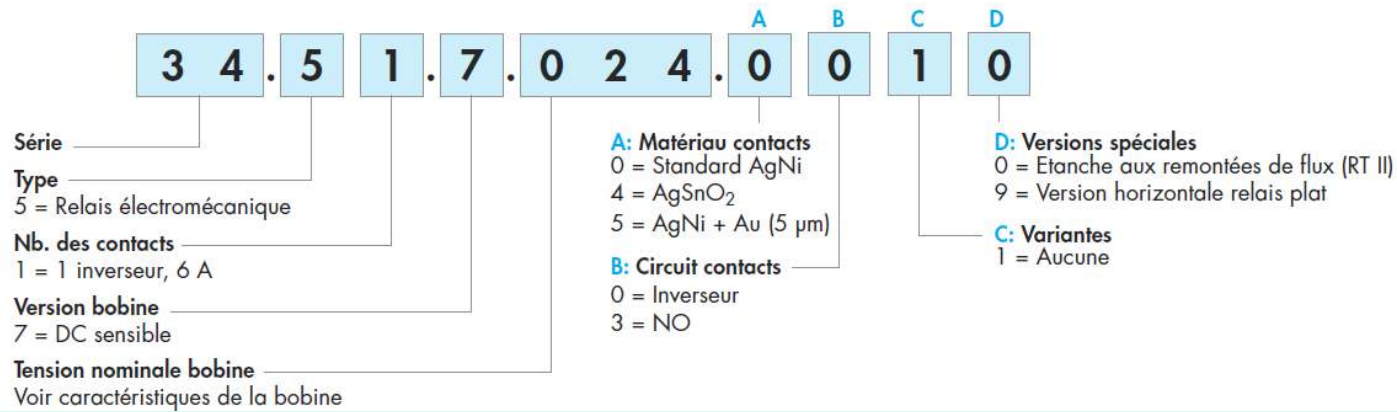

### Données version DC

Tension nominale $U_N$ V	Code bobine	Plage de fonctionnement		Résistance R Ω	I nominale absorbée à $U_N$ mA
		$U_{min}$ V	$U_{max}$ V		
5	7.005	3.5	7.5	130	38.4
12	7.012	8.4	18	840	14.2
24	7.024	16.8	36	3350	7.1
48	7.048	33.6	72	12300	3.9
60	7.060	42	90	19700	3

## Relais 34.1.7024.0010

1. Type : Relais électromécanique
2. Tension de bobine : 24 V C.C.
3. Résistance de bobine : 3,35kΩ
4. Courant nominale : 6A
5. Tension de contact : 250V C.A.
6. Matériel de contact. : AgSnO<sub>2</sub>

# أكمل

1. ....
2. ....
3. ....
4. ....
5. ....

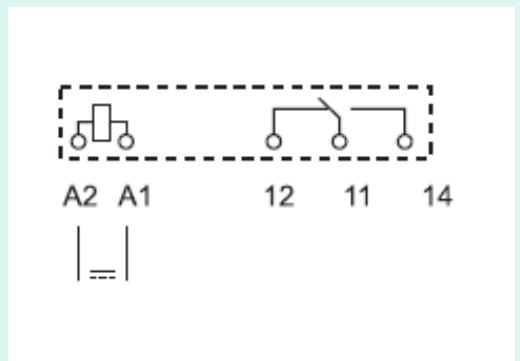

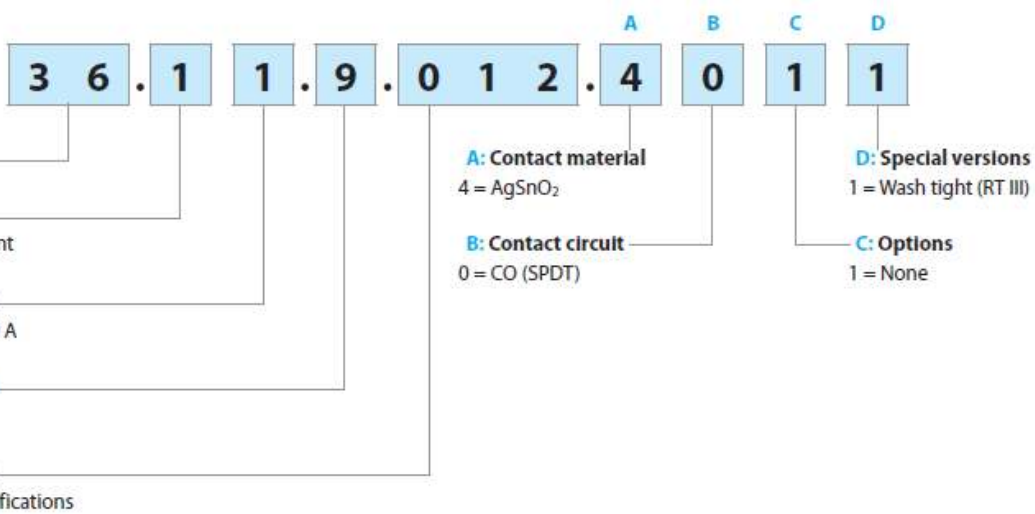

36.11.9.005.4011

- |                            |                      |
|----------------------------|----------------------|
| 1. Type                    | : 36.11.9.005.4011   |
| 2. Tension de bobine       | : 5VDC               |
| 3. Résistance de la bobine | : 70Ω                |
| 4. Tension de contact      | : 250VAC             |
| 5. Courant nominale        | : 10A                |
| 6. Matériel de contact     | : AgSnO <sub>2</sub> |

#### DC coil data

Nominal voltage $U_N$ V	Coil code	Operating range		Resistance R Ω	Rated coil consumption I at $U_N$ mA
		$U_{min}$ V	$U_{max}$ V		
3	9.003	2.2	4.5	25	120
5	9.005	3.7	7.5	70	72
6	9.006	4.5	9	100	60
9	9.009	6.7	13.5	225	40
12	9.012	9	18	400	30
24	9.024	18	36	1,600	15
48	9.048	36	72	6,400	7.5

# أكمل

1. ....
2. ....
3. ....
4. ....
5. ....

# TYPES AND COIL DATA at 20°C 68°F

Part No.	Nominal voltage, V DC	Pick-up voltage, V DC (max.)	Drop-out voltage, V DC (min.)	Nominal operating current, mA ( $\pm 10\%$ )	Nominal operating power, mW	Coil resistance, $\Omega$ ( $\pm 10\%$ )	Maximum allowable voltage, V DC
HB1E-DC3V	3	2.4	0.3	120	360	25	3.6
HB1E-DC5V	5	4.0	0.5	72	360	69	6.0
HB1E-DC6V	6	4.8	0.6	60	360	100	7.2
HB1E-DC9V	9	7.2	0.9	40	360	225	10.8
HB1E-DC12V	12	9.6	1.2	30	360	400	14.4
HB1E-DC24V	24	19.2	2.4	15	360	1,600	28.8
HB1E-DC48V	48	38.4	4.8	8	384	6,000	57.6
HB2E-DC3V	3	2.4	0.3	192	576	15.6	3.6
HB2E-DC5V	5	4.0	0.5	115	576	43.4	6.0
HB2E-DC6V	6	4.8	0.6	96	576	62.5	7.2
HB2E-DC9V	9	7.2	0.9	69	623	130	10.8
HB2E-DC12V	12	9.6	1.2	48	576	250	14.4
HB2E-DC24V	24	19.2	2.4	24	576	1,000	28.8
HB2E-DC48V	48	38.4	4.8	12	576	4,000	57.6

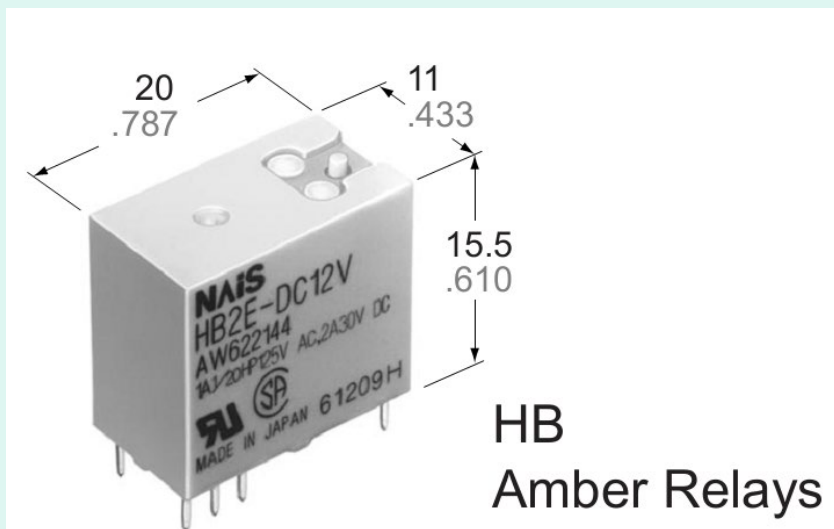

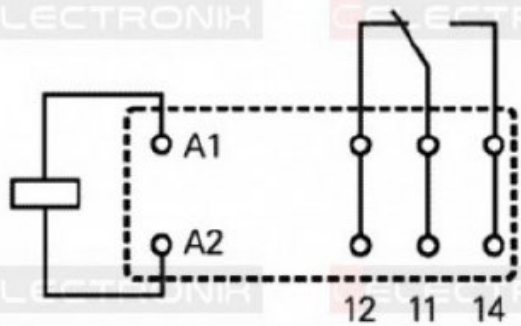

Forme du contact de relais:	1 Forme C (SPDT-NO, NC)
Courant nominal du contact:	16 A
Raccordement du contact:	Broche à souder
Style de montage:	À travers le trou
Tension de commutation:	250 VCA
Raccordement de la bobine:	Broche à souder
Type de bobine:	Non verrouillable
Résistance de la bobine:	62 Ohms
Matériau du contact:	Nickel argenté (AgNi)
Longueur:	29 mm
Largeur:	12.7 mm
Hauteur:	15.7 mm
Conditionnement:	Masse
Forme du contact:	SPDT (1 forme C)
Interruption alimentation max.:	30 A
Consommation d'énergie:	400 mW
Marque:	TE Connectivity / Schrack
Type de produit:	Relais à usage général
Raccourcis pour l'article N°:	9-1393239-1

Relais 5V 16A SPDT, SCHRACK RT314005

## Relais 5V 16A SPDT, SCHRACK RT314005

1. Type : SCHRACK RT314005
2. Tension de bobine : 5VDC
3. Résistance de la bobine : 168 $\Omega$
4. Contact Configuration : DPDT
5. Type de montage : Montage PCB
6. Courant de commutation : 16A
7. Tension de commutation : 250V
8. Forme du contact de relais : 1 Forme C (SPDT-NO, NC)
9. Matériau du contact : Nickel argenté (AgNi)
10. Type : Miniature
11. Consommation d'énergie : 400 mW
12. Type de produit : Relais à usage général

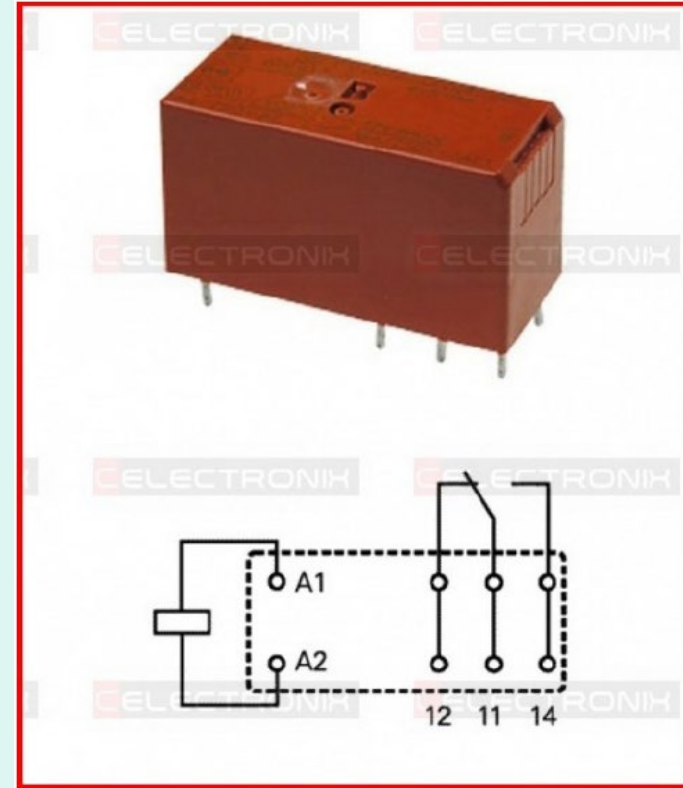

# PCB Power Relay – G2R

## Model Number Legend

G2R  -     -   -    VDC  
1 2 3 4 5 6 7 8 9

### 1. Relay Function

- None: Single-side stable
- K: Double-winding latching

### 2. Number of Poles

- 1: 1 pole
- 2: 2 poles

### 3. Contact Form

- None: PDT
- A: PST-NO

### 4. Contact Type

- None: Single
- Z: Bifurcated

### 5. Enclosure Ratings

- None: Flux protection
- 4: Fully sealed

### 6. Terminals

- None: Straight PCB
- T: Quick-connect (upper bracket mounting)

### 7. Classification

- None: General-purpose
- E: High-capacity
- H: High-sensitivity

### 8. Safety Standards

- None: UL/CSA/EN/SEV/TÜV
- SKVD: UL/CSA/EN/SEV/TÜV/SEMKO

### 9. Rated Coil Voltage

- Refer to Coil Ratings

# Désignations

## ■ Légende.

G2R     -   -

1 2 3 4 5 6 7

### 1. Fonctions des relais

Absence d'indication : Relais standard

### 2. Nombre de pôles

1: 1 pôle

2: 2 pôles

### 3. Forme du contact

Rien : SPDT

### 4. Type de contact

Rien : simple

### 5. Bornes

S : embrochable

### 6. Catégorie

Absence d'indication : relais standard

N : voyant DEL

D : diode

ND : voyant DEL et diode

NI : voyant DEL avec bouton de test

NDI : voyant DEL et diode avec bouton de test

### 7. Tension nominale de la bobine

# Spécifications

## ■ Données nominales de la bobine

Tension nominale	Courant nominal*		Résistance bobine*	Inductance de la bobine (H) (valeur de référence)		Tension d'enclenchement	Tension de relâchement	Tension max.	Puissance consommée (approximative)	
	50 Hz	60 Hz		Repos	Travail					% de la tension nominale
c.a.	24 V	43,5 mA	37,4 mA	253 Ω	0,81	1,55	80 % maximum	30 % maximum	110 %	0,9 VA à 60 Hz
	110 V	9,5 mA	8,2 mA	5 566 Ω	13,33	26,83				
	120 V	8,6 mA	7,5 mA	7 286 Ω	16,13	32,46				
	230 V	4,4 mA	3,8 mA	27 172 Ω	72,68	143,90				
	240 V	3,7 mA	3,2 mA	30 360 Ω	90,58	182,34				

Tension nominale	Courant nominal*		Résistance bobine*	Inductance de la bobine (H) (valeur de référence)		Tension d'enclenchement	Tension de relâchement	Tension max.	Puissance consommée (approximative)
	Repos	Travail		% de la tension nominale					
c.c.	6 V	87,0 mA	69 Ω	0,25	0,48	70 % maximum	15 % minimum	110 %	0,53 W
	12 V	43,2 mA	278 Ω	0,98	2,35				
	24 V	21,6 mA	1 113 Ω	3,60	8,25				
	48 V	11,4 mA	4 220 Ω	15,2	29,82				

\*Le courant nominal et la résistance bobine sont mesurés à une température de bobine de 23°C, avec une tolérance de ±10 %.

## ■ Valeurs nominales des contacts

Nombre de pôles	1 pôle		2 pôles	
	Charge résistive ( $\cos\phi = 1$ )	Charge inductive ( $\cos\phi = 0,4$ ; $L/R = 7$ ms)	Charge résistive ( $\cos\phi = 1$ )	Charge inductive ( $\cos\phi = 0,4$ ; $L/R = 7$ ms)
Charge nominale	10 A à 250 Vc.a. ; 10 A à 30 Vc.c.	7,5 A à 250 Vc.a. ; 5 A à 30 Vc.c.	5 A à 250 Vc.a. ; 5 A à 30 Vc.c.	2 A à 250 Vc.a. ; 3 A à 30 Vc.c.
Courant de charge nominal	10 A		5 A	
Tension de commutation max.	440 Vc.a., 125 Vc.c.		380 Vc.a., 125 Vc.c.	
Courant de commutation max.	10 A		5 A	
Puissance de commutation max.	2 500 Vc.a., 300 W	1 875 VA, 150 W	1 250 VA, 150 W	500 VA, 90 W
Taux de défaillance (valeur de référence)	100 mA à 5 Vc.c.		10 mA à 5 Vc.c.	

## Références

### ■ Liste des modèles

Catégorie		Degré d'étanchéité	Données nominales de la bobine	Forme du contact	
				SPDT	DPDT
Borne embrochable	Modèle standard	Non étanche	c.a./c.c.	G2R-1-S	G2R-2-S
	Voyant DEL			G2R-1-SN	G2R-2-SN
	Voyant DEL avec bouton de test			G2R-1-SNI	G2R-2-SNI
	Diode		c.c.	G2R-1-SD	G2R-2-SD
	Voyant DEL et diode			G2R-1-SND	G2R-2-SND
	Voyant DEL et diode avec bouton de test			G2R-1-SNDI	G2R-2-SNDI

**Note :** lors de la commande, ajoutez la tension nominale de la bobine et le symbole "(S)" à la référence du modèle.

Les tensions nominales des bobines sont indiquées dans le tableau des données nominales des bobines.

Exemple : G2R-1-S 12 Vc.c. (S) — Nouveau modèle

         Tension nominale de la bobine

# G5LE

PCB Power Relay

## Ordering Information

Terminal Shape	Classification	Enclosure rating Contact form	Flux protection		Fully sealed		Minimun packing unit
			Model	Rated coil voltage	Model	Rated coil voltage	
PCB terminals	Standard	SPDT (1c)	G5LE-1	5 VDC	G5LE-14	5 VDC	100 pcs/tray
				12 VDC		12 VDC	
				24 VDC		24 VDC	
		SPST-NO (1a)	G5LE-1-CF	5 VDC	G5LE-14-CF	5 VDC	
				12 VDC		12 VDC	
				24 VDC		24 VDC	
	High capacity	SPDT (1c)	G5LE-1A	5 VDC	G5LE-1A4	5 VDC	
				12 VDC		12 VDC	
				24 VDC		24 VDC	
		SPST-NO (1a)	G5LE-1A-CF	5 VDC	G5LE-1A4-CF	5 VDC	
				12 VDC		12 VDC	
				24 VDC		24 VDC	
SPDT (1c)	G5LE-1-E	5 VDC	---				
		12 VDC					
		24 VDC					
SPST-NO (1a)	G5LE-1A-E	5 VDC	---				
		12 VDC					
		24 VDC					

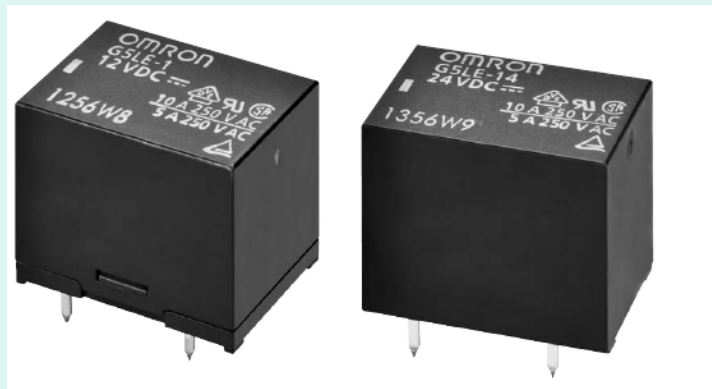

## Relais 24V G5LE-24V

1. Relais électromécanique 1x250V 10A 24VDC G5LE1VD24DC.
2. Constructeur: OMRON.
3. Code constructeur: G5LE-1VD-24VDC.
4. Série: G5LE-1.
5. Type de relais: relais électromécanique standard.
6. tension d'alimentation bobine: 24 V. bobine DC/AC: VDC.
7. résistance de la bobine: 1440 Ohm. bobine: 1. bobine:1440R 16.7mA.
8. Longueur/ largeur/ hauteur: 22x16x19mm.
9. capacité: 10A/250VAC, 8A/125VDC.
10. Fonctionnement :on /on.
11. Plage de température de fonctionnement: -40°C à +80°C.
12. Matériau des contacts: AgSnO<sub>2</sub>. Stock
13. Produit garanti d'origine constructeur Omron.



## Relais 24V G5LE-24V

1. Relais électromécanique 1x250V 10A 24VDC G5LE1VD24DC.
2. Constructeur: OMRON.
3. Code constructeur: G5LE-1VD-24VDC.
4. Série: G5LE-1.
5. Type de relais: relais électromécanique standard.
6. tension d'alimentation bobine: 24 V. bobine DC/AC: VDC.
7. résistance de la bobine: 1440 Ohm. bobine: 1. bobine:1440R 16.7mA.
8. Longueur/ largeur/ hauteur: 22x16x19mm.
9. capacité: 10A/250VAC, 8A/125VDC.
10. Fonctionnement :on /on.
11. Plage de température de fonctionnement: -40°C à +80°C.
12. Matériau des contacts: AgSnO<sub>2</sub>. Stock
13. Produit garanti d'origine constructeur Omron.



## Relais 5V G2R1E-5V. Avtronic

1. Type : **G2R1E5DC**
2. Constructeur : OMRON
3. Code constructeur : G2R-1-E-5DC. Série: G2R-1-E
4. Type de relais : relais électromécanique standard
5. Tension de bobine : 5VDC
6. Résistance de la bobine :  $47\Omega$
7. Consommation d'énergie : 640mW
8. Longueur/ largeur/ hauteur : 29x13x25mm
9. température de fonctionnement:  $-40^{\circ}\text{C}$  à  $+70^{\circ}\text{C}$ .
10. Matériau des contacts : AgCdO



1. Type	: <b><u>G2R-1 12VDC OMRON OCB</u></b>
2. Fabricant	: OMRON OCB
3. Type de relais	: électromagnétique
4. Contacts configuration	: SPDT
5. Tension nominale de la bobine	: 12 V CC
6. Classification des contacts AC @R(à charge résistive)	: 10A / 250V AC
7. Puissance des contacts CC @R (à charge résistive)	: 10A / 30V DC
8. Courant de contact max	: 10A
9. Tension commutée max	: 125 V CC, max. 380V AC
10. Montage	: PCB
11. Résistance de la bobine	: 275Ω
12. Temps de fonctionnement	: 15 ms
13. Dimensions du corps	: 29x13x25,5 mm
14. Temps de libération	: 5 ms
15. Température de fonctionnement	: -40...70°C
16. Série de relais	: G2R
17. Résistance de contact	: 30 mΩ
18. Pas terminal	: 3,5 mm
19. Courant de bobine	: 43,6 mA





## Relais de puissance, Omron Electronics Inc-EMC Div G2R-1-DC24

### Relais G2R-1-DC24

1. Relais de puissance : plus de 2 A
2. Fabricant : Omron Electronics Inc-EMC Div
3. Série : G2R
4. Tension de bobine : 24V CC
5. Forme de contact : SPDT (1 forme C)
6. Capacité des contacts (courant) : 10A
7. Tension de commutation : 380V CA, 125V CC – maxi
8. Durée de fonctionnement : 15ms
9. Temps de relâchement : 5ms
10. Température de fonctionnement : -40°C ~ 70°C
11. Matériau de contact : Alliage d'argent
12. Type de relais : Usage général
13. Résistance de bobine : 1100 kOhms

## Relais 48V G2R1-48V



1. Type de relais : **Relais électromécanique 1x250V 10A 48VDC G2R-1.**
2. Constructeur : OMRON.
3. Relais : relais électromécanique standard.
4. tension d'alimentation bobine : 48 V. bobine DC/AC: VDC.
5. résistance de la bobine : 4170 Ohm. bobine: 1. bobine: 4170R 11.5mA.
6. Longueur/ largeur/ hauteur : 29x13x25.5mm. capacité:
7. Max.VAC : 400V.
8. Fonctionnement : on/on.
9. Produit garanti d'origine constructeur: Omron.

### Relais 24V G2R1-24V



5.55€ TTC

✓ 60 En stock

Relais électromécanique 1x250V 10A 24VDC  
G2R-1. Constructeur: [OMRON...](#)

### Relais 5V 405290050000



11.45€ TTC

✓ 34 En stock

Relais électromécanique 2x250V 8A/15A  
5VDC. Constructeur: [Finder...](#)



## Description du produit

Carte électronique de commutateur de  
Module de contrôle de pression  
automatique de pompe à eau de 1pc

Pompe à eau AC220V ~ 240V | Module  
de contrôle de pression automatique,  
panneau de commande de  
commutateur de pression électr...

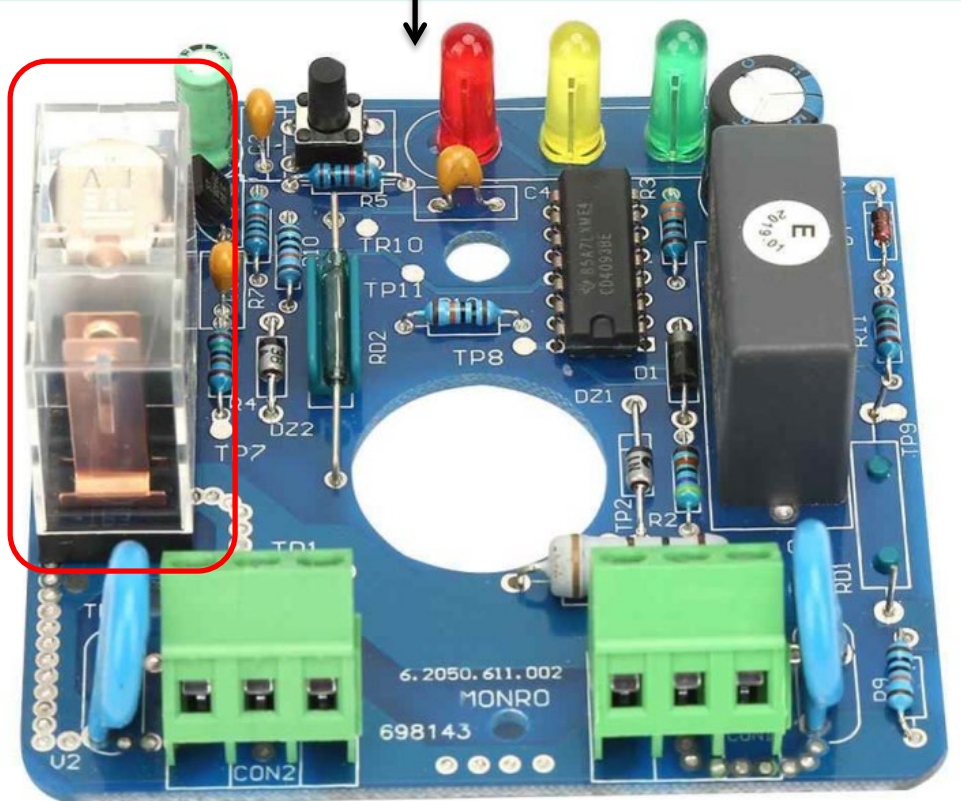

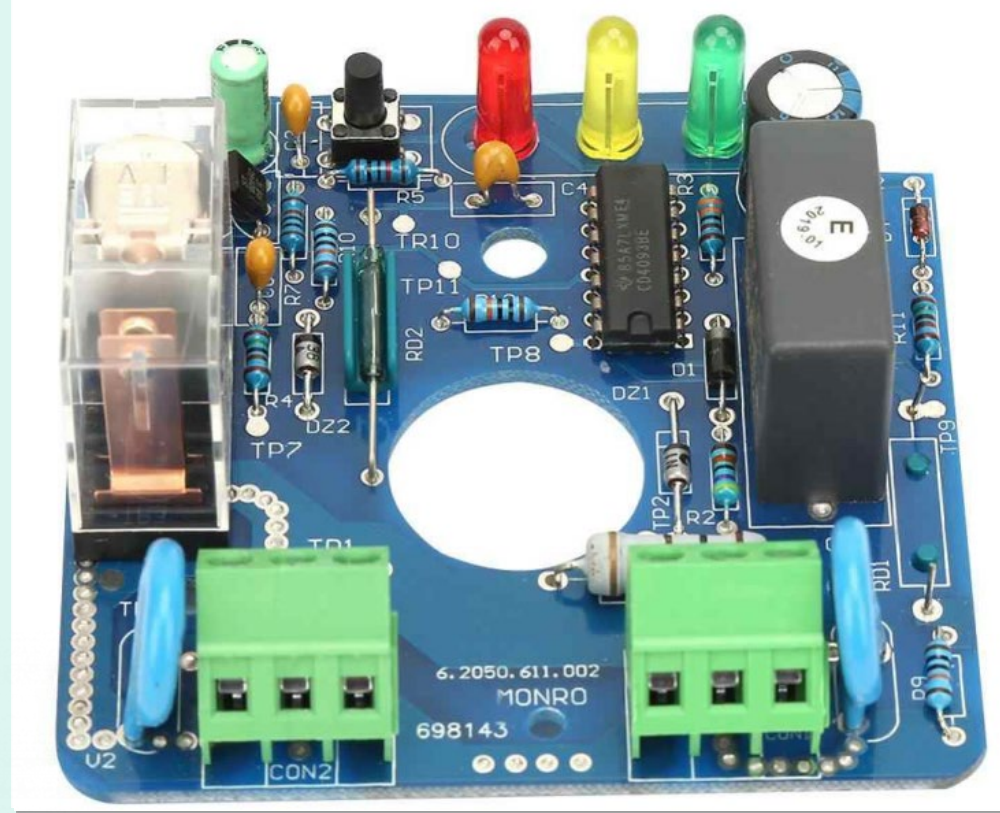

## Tension de bobine du relais

Pour chaque relais, il existe une tension de bobine. Elle peut être continue (5V, 12V, etc) ou alternative (110V, 230V). C'est la tension qu'il faut appliquer sur la bobine pour faire commuter le relais (entendre le "clic"). Le courant consommé dépend du type de relais et est inversement proportionnel à la tension de bobine. Dans une gamme de relais (5V, 12V, 24V, etc), la puissance de la bobine est constante. Par exemple : 12V 40mA, 24V 20mA, 48V 10mA, etc...

Pour déterminer le courant consommé par la bobine, il suffit de mesurer la résistance à l'ohmmètre et déduire le courant. C'est utile pour dimensionner l'alimentation de la commande (montage qui pilote la bobine du relais).

Sur la plupart des relais, il existe une large tolérance sur la tension de bobine. La tension va souvent de 70% à 150% (ou même 200%) de la tension nominale. Une tension trop faible ne permet pas de garantir un bon contact. Une tension trop élevée va faire griller la bobine !

## Exemples de relais

Relais alimenté en 12V : on peut l'alimenter de 70% à 150% de sa tension nominale de bobine (8,4V à 18V)

Relais alimenté en 5V : 3,5V - 7,5V

Pas besoin d'une alimentation régulée de précision pour faire commuter un relais !

Le pilotage de la bobine par un transistor bipolaire NPN (le plus classique) nécessite l'ajout d'une diode de roue libre en parallèle avec la bobine du relais :

## Polarité de la tension de bobine

Sur la plupart des relais, la tension continue peut être appliquée dans n'importe quel sens sur la bobine. Il existe de très rares exceptions où la bobine du relais est polarisée. Si on applique la tension à l'envers, le relais ne commute pas.

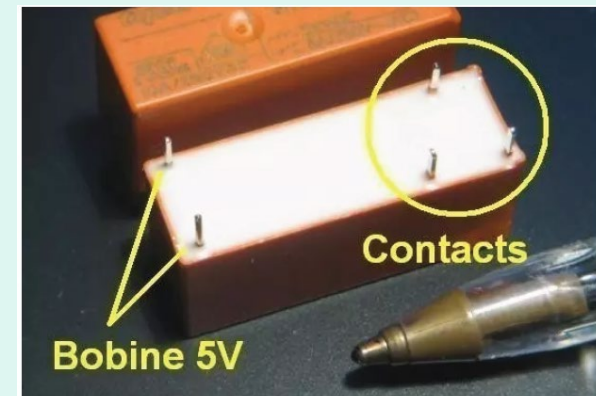
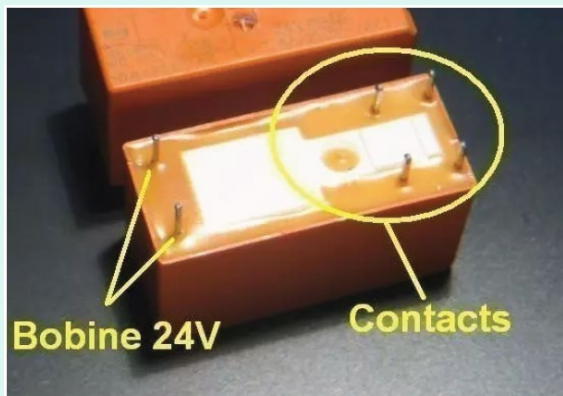

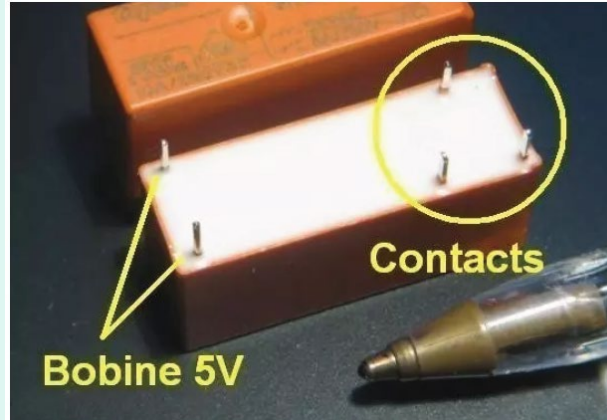
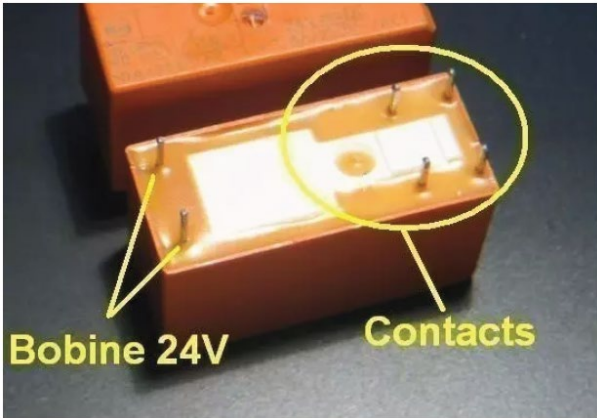

Un relais électronique est un interrupteur qui se commande avec une tension continue ou alternative de faible puissance. La partie interrupteur sert à piloter des charges secteur de forte puissance, jusqu'à 10 ou 16 Ampères couramment.

Les contacts des relais sont décrits avec d'une façon précise. De quoi s'agit-il lorsqu'on parle de relais **SPST** ou **DPDT** ?

### Type et abréviations des relais

Lorsqu'on choisit ou qu'on récupère un relais, il est nécessaire de savoir de quel type de connexion il s'agit. Il existe 4 grandes familles de relais, en fonction des contacts

### Relais SPST

SPST : Single Pole Single Throw.

Le relais SPST possède 2 broches de contacts. Dans ce cas, le relais possède 4 broches au total : 2 pour les contacts, 2 pour la bobine

### Exemple de relais SPST

ce type de relais ne peut commuter qu'une seule voie. Par exemple, il peut allumer ou éteindre une lampe (couper la phase OU le neutre).

## Relais SPDT

SPDT : Single Pole Double Throw.

Le relais SPDT possède un seul contact mais avec une borne commune, un contact normalement ouvert (quand il n'y a pas de tension sur la bobine) et un contact normalement fermé (quand il n'y a pas de tension sur la bobine). Quand on applique une tension sur la bobine, on entend "clic" : la borne commune va se connecter sur le contact normalement ouvert (NO = normally open) et le contact normalement fermé (NC = normally closed) s'ouvre. Dès qu'on coupe la tension aux bornes de la bobine, on entend "clic" et le relais revient à son état de repos. On peut ainsi basculer d'un circuit à l'autre (allumer soit l'ampoule rouge soit l'ampoule verte par exemple).

Le relais SPDT possède 5 broches au total : 3 pour les contacts, 2 pour la bobine

### Exemple de relais SPDT

Si on n'utilise pas le contact "normalement fermé" le relais SPDT est équivalent à un relais SPST..

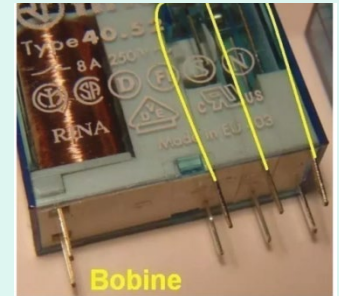

## Relais DPST

DPST : Double Pole Single Throw.

Le relais DPST est équivalent à 2 relais SPST qui fonctionnent ensemble, pilotés par la même bobine. On peut par exemple commuter 2 circuits indépendants en même temps par la même action (appliquer 12 Volts sur la bobine par exemple), ou commuter à la fois phase et neutre pour brancher un circuit électrique au secteur.

Le relais DPST possède 6 broches au total : 2 x 2 pour les contacts, 2 pour la bobine.

### Exemple de relais DPST

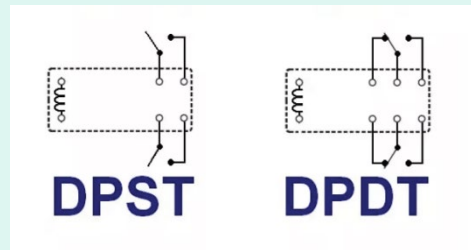

## Relais DPDT

DPDT : Double Pole Double Throw.

Le relais DPDT est équivalent à 2 relais SPDT qui fonctionnent ensemble, pilotés par la même bobine. Le relais DPDT possède 8 broches au total : 2x3 pour les contacts, 2 pour la bobine.

### Exemple de relais DPDT

La lettre "S" ou "D" peuvent être remplacées par le nombre de contacts pilotés ensemble. Par exemple : 4PDT signifie 4 ensembles DT (12 bornes de contacts + 2 bornes de bobine).

A la place de "DT", on rencontre parfois "CO" (change-over)

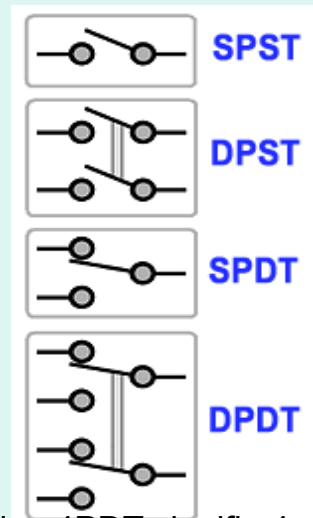

## Défaillance des relais:

Lorsqu'un relais ne fonctionne plus, il se peut qu'on entende toujours le "clic". On peut penser que le relais est encore bon et chercher la panne ailleurs. Pourtant, malgré le "clic", il ne se produit plus de contact. C'est parfois un piège !

On peut aussi vérifier la continuité de la bobine en mesurant à l'ohmmètre la résistance entre les 2 broches de la bobine (valeurs courantes entre 100 Ohms et quelques kOhms).

Exemple : panne de relais sur un lit motorisé Linak (relais HS)

Symptôme de la panne : "clic" audible dans le module Linak lors de l'appui sur le bouton de la commande pour faire monter ou descendre le lit mais le moteur ne se met pas en route.

Solution : remplacer les relais en faisant attention de choisir le bon modèle (SPST vs. SPDT).

Vérifier l'état du transistor MOSFET en boîtier TO220 sur la carte électronique.

## Charges pilotables par les relais

Les relais peuvent souvent commuter un courant élevé sur de l'alternatif (250V AC), en revanche, ils ne commutent pas de tension supérieures à 20 ou 30V continus environ. Bien sur, cela dépend des modèles, mais il faut retenir que commuter une charge en tension et courant continu est une opération délicate (coupure de courant issu de panneaux solaires ou de batteries). L'arc engendré à l'existence des relais statiques : ce sont des composants qui ont la même fonction qu'un relais à bobine et contacts mais sans élément mécanique. Le contact est assuré par la conduction d'un triac piloté par optocoupleur pour garantir l'isolement électrique entre commande et puissance :

Il existe des relais statiques : ce sont des composants qui ont la même fonction qu'un relais à bobine et contacts mais sans élément mécanique. Le contact est assuré par la conduction d'un triac piloté par optocoupleur pour garantir l'isolement électrique entre commande et puissance :

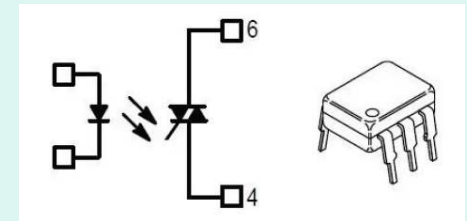

## Relais statique

Le courant maximum du côté des contacts est plus faible : un triac possède une chute de tension de 1V environ contrairement à des contacts d'un relais mécanique à bobine. Il y a aussi un très léger courant de fuite lorsque la LED n'est pas pilotée (LED éteinte). Ce courant est de 1 nA à 100 nA couramment.

Exemple de relais statique : MOC3041 et MOC3042

**1 :** On souhaite commander une lampe à partir de la sortie parallèle du PC

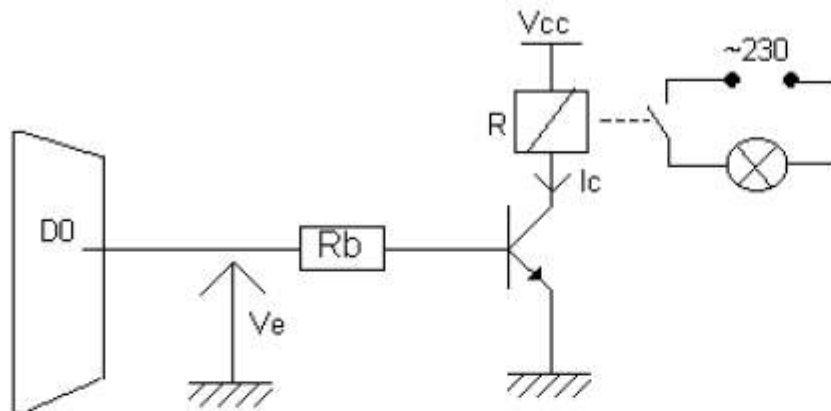

On donne :

- $V_{cc} = 10\text{ V}$
- $R = 100\ \Omega$  (résistance du relais)
- $V_{cesat} = 0.1\text{ V}$
- $V_{besat} = 0.7\text{ V}$
- $V_e = 5\text{ V}$
- $\beta = 100$

1- Placer  $V_{be}$ ,  $V_{ce}$  et  $I_b$  sur le schéma.

2- Calculer la valeur de  $I_c$  (sachant que  $I_c = \beta \cdot I_b$ )

.....

3- En déduire la valeur de  $I_b$

.....

4- Calculer  $R_b$ .

.....

5- Justifier le rôle du transistor sachant que le courant délivré par la sortie du port parallèle ne peut excéder une quinzaine de milliampère.

.....

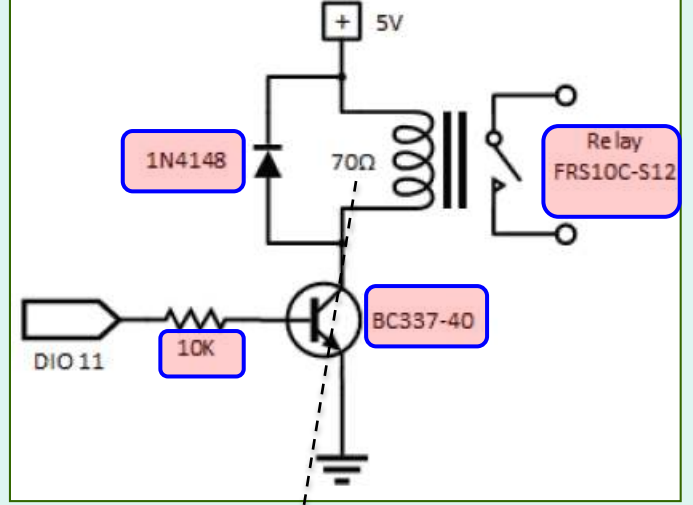
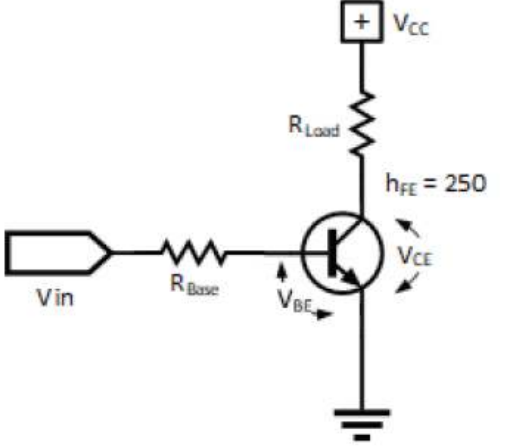

**Characteristics of 1N4148 Diode**

1. Type Diode: Diode à commutation rapide épitaxiale au silicium
2. La tension inverse répétitive maximale est : 100 volts
3. Le courant rectifié moyen maximum est : 15 A ou 150 mA
4. La dissipation de puissance maximale est : 5 W
5. La tension inverse est : 75 V
6. La température de fonctionnement devrait être : -65 à +175

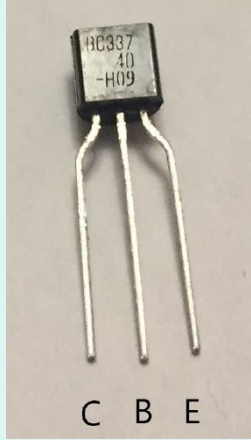

RATED VOLTAGE (V DC)	COIL RESISTANCE $\Omega$ +/- 10 %	RATED CURRENT (mA)	POWER CONSUMPTION (W)
3	25	120	0.36 Approx.
5	70	70	
6	100	60	
9	220	40	
12	400	30	
24	1600	15	
48	6400	7.5	

**Characteristics of BC337-40 Transistor**

1. Package Type: TO-92
2. Transistor Type: NPN
3. Max Collector Current (I<sub>C</sub>): 0.8A or 800mA
4. Max Collector-Emitter Voltage (V<sub>CE</sub>): 45V
5. Max Collector-Base Voltage (V<sub>CB</sub>): 50V
6. Max Emitter-Base Voltage (V<sub>BE</sub>): 5V
7. Max Collector Dissipation (P<sub>c</sub>): 625 mWatt
8. Max Transition Frequency (f<sub>T</sub>): 100 MHz
9. Minimum & Maximum DC Current Gain (h<sub>FE</sub>): 100 – 630
10. Temperature : -55 to +150

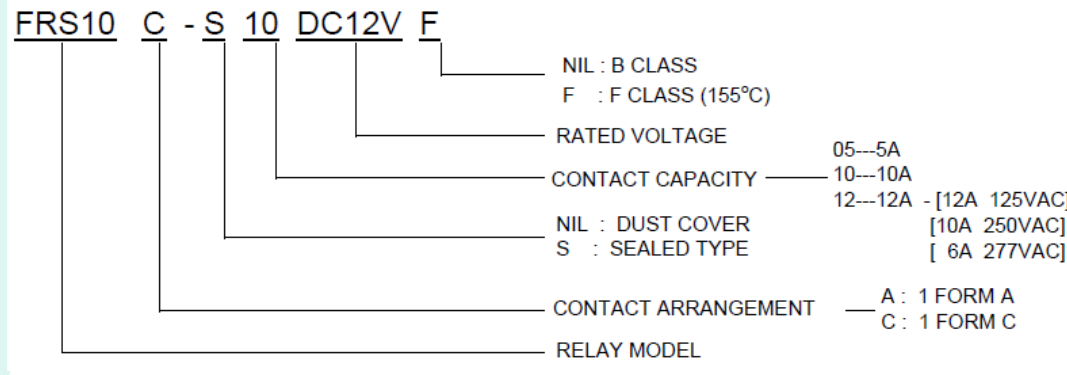

## مرحل خاص بالسيارات

### C04-80A-12V

Contact Material : AgSnO12

Contact Form : Open 1Z 1H

Contact Rating : NO:DC12V-80A  
NC:DC12V-60A

Max Switching Current : 90A

Max Switching Voltage : 14V

Max Switching Power : 1260W

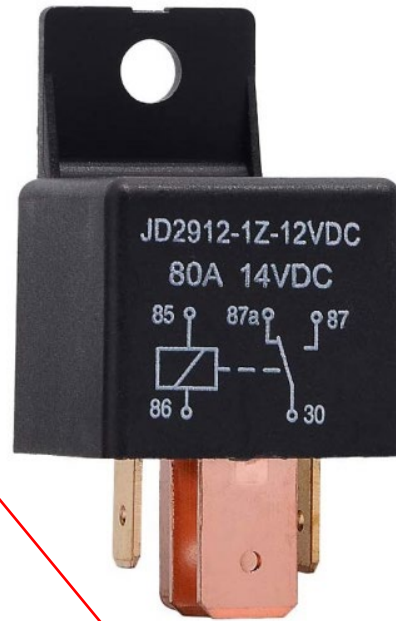

مرحل خاص بالسيارات يتميز بتيار كبير  
يتلائم مع تيار البطارية الكبير

## مرحل خاص بالسيارات

relais-spdt-24v-30a-automobile.jpg

### Caractéristiques:

- 5Pin
- Couleur: bleu
- Puissance de la bobine: 1.8W
- Courant de commutation évalué: 40A
- Tension nominale: cc 24V
- Entre les Contacts force diélectrique: 550V ca
- Entre la bobine et la force diélectrique de contactsdiélectrique: 750V ca
- Résistance d'isolation: 100 O
- Dimension externe: 29\*28\*24.5
- Température de fonctionnement: -40 ~ 85 Celsius
- Forme terminale: Type de prise, PC
- Mode coque: coque plate, dossier Lron, dossier plastique
- Ajustement universel pour la plupart des voitures ou des moteurs

### JD2914 24V 40A 5Pin Car Relay

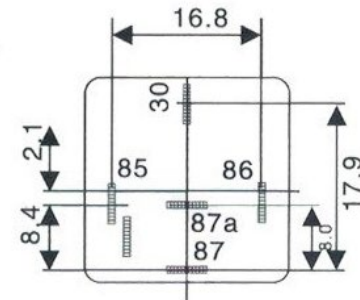
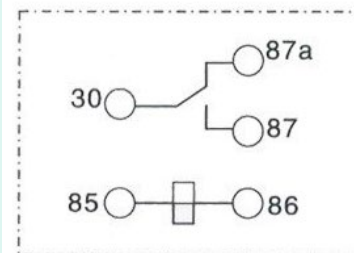

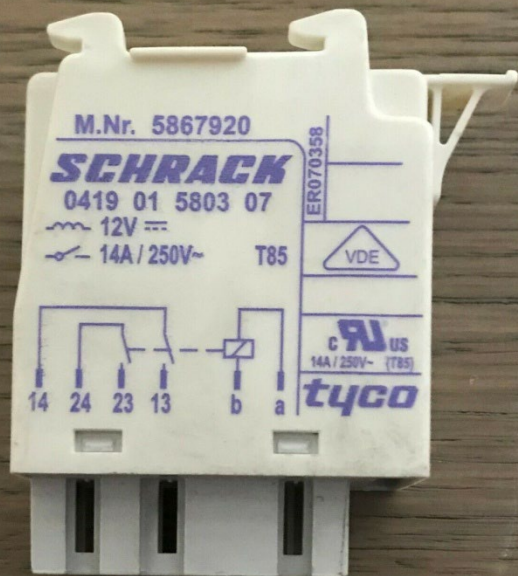

## مرحل آلة الغسيل

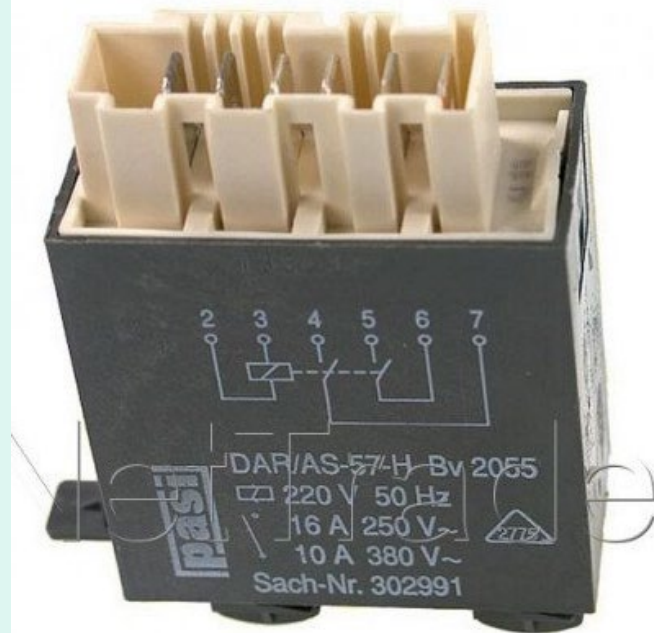

Sensitive (200mW)

Order Number	Coil Voltage VDC	Pick-up Voltage VDC (Max.)	Drop-out Voltage VDC (Min.)	Coil Resistance $\Omega$ $\pm 10\%$	
003-S	3	2.25	0.3	45	
005-S	5	3.75	0.5	125	
006-S	6	4.50	0.6	180	
009-S	9	6.80	0.9	405	18
<b>012-S</b>	<b>12</b>	<b>9.00</b>	<b>1.2</b>	<b>720</b>	<b>24</b>
015-S	15	11.3	1.5	1125	30
024-S	24	18.0	2.4	2880	48



Standard (360mW) 20°C

Coil Voltage VDC	Pick-up Voltage VDC (Max.)	Drop-out Voltage VDC (Min.)	Coil Resistance $\Omega$ $\pm 10\%$	Allow Voltage VDC (Max.)
3	2.25	0.3	30	4.5
5	3.75	0.5	90	8.0
6	4.50	0.6	130	10.0
009-M	9	6.80	280	14.5
<b>012-M</b>	<b>12</b>	<b>9.00</b>	<b>450</b>	<b>18.5</b>
015-M	15	11.3	625	22.0
024-M	24	18.0	1600	35.5
048-M	48	36.0	4000	56.0

**JRC-27F/012.S**

- Type : JRC-27F/012.S
- Tension de bobine : 12VDC
- Résistance de la bobine : 720 $\Omega$
- Puissance : 200mW
- Courant de commutation : 2A
- température de fonctionnement : -40°C to +85°C

**JRC-27F/012.M**

- Type : JRC-27F/012.M
- Tension de bobine : 12VDC
- Résistance de la bobine : 450 $\Omega$
- Puissance : 360mW
- Courant de commutation : 2A
- température de fonctionnement : -40°C to +85°C

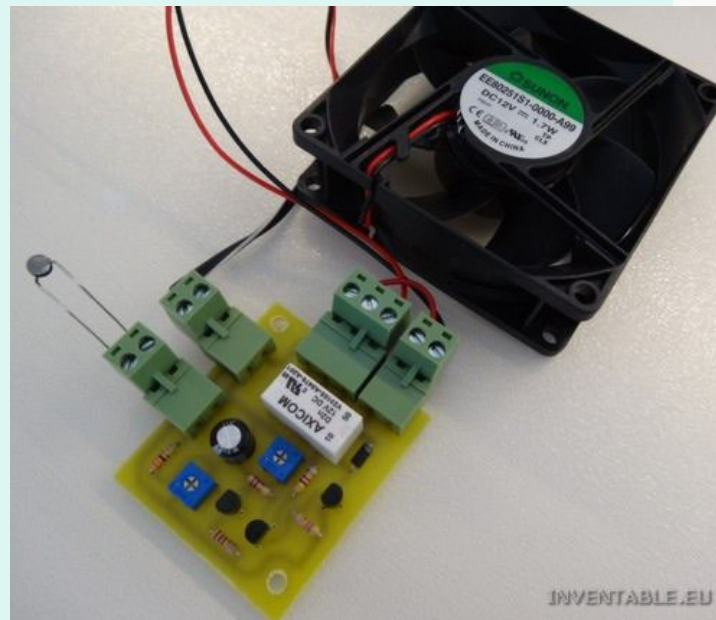
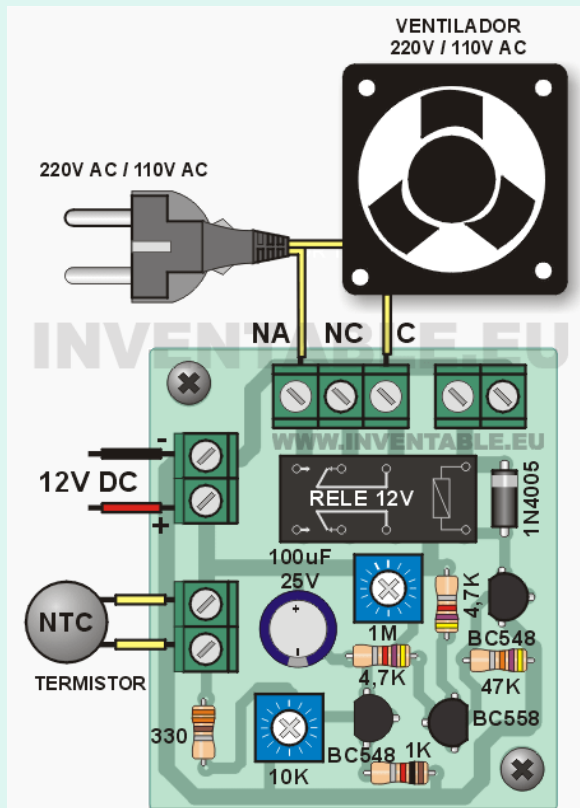
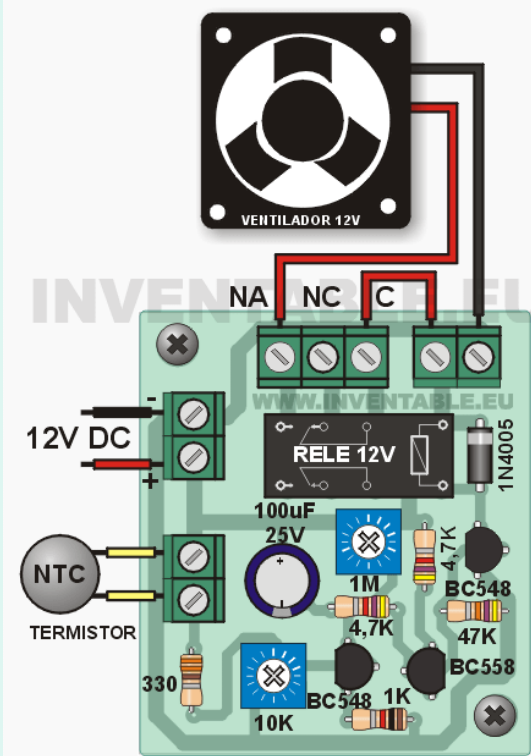
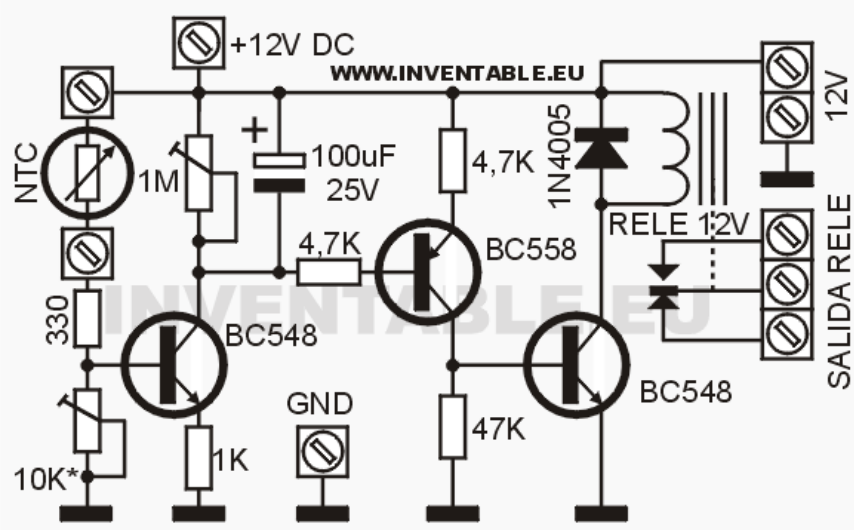

### **V23105-A5303-A201**

1. Tension de bobine: 12VDC
2. Configuration des contacts: DPDT
3. Courant de contact: 3A
4. Gamme de produit: Série D2n/V23105
5. Montage relais: Traversant
6. Type de bobine: Non verrouillable
7. Bornes de relais: A souder
8. Tension de contact AC: 250V
9. Tension de contact DC: 220V
10. Matériau du contact: Argent nickel
11. Résistance, bobine: 720ohm

### **V23092-A1024-A801**

1. Configuration des contacts: SPDT
2. Tension de bobine: 24VDC
3. Courant de contact: 6A
4. Gamme de produit: SNR/V23092 Series
5. Montage relais: Traversant
6. Type de bobine: Non verrouillable
7. Tension de contact AC: 250V
8. Bornes de relais: A souder
9. Matériau du contact: Argent nickel
10. Résistance, bobine: 3.39kohm

### **V23079E1208B301**

1. Tension de bobine: 3VDC
2. Configuration des contacts: DPDT
3. Courant de contact: 2A
4. Gamme de produit: P2/V23079 Series
5. Montage relais: Montage en surface
6. Type de bobine: Bobine double verrouillable
7. Bornes de relais: A souder
8. Tension de contact AC: 250V Configuration des contacts: SPDT
9. Tension de bobine: 24VDC
10. Courant de contact: 6A
11. Gamme de produit: SNR/V23092 Series
12. Montage relais: Traversant
13. Type de bobine: Non verrouillable
14. Tension de contact AC: 250V
15. Bornes de relais: A souder
16. Tension de contact DC: -
17. Matériau du contact: Argent nickel
18. Résistance, bobine: 3.39kohm
19. Tension de contact DC: 220V
20. Matériau du contact: Argent nickel
21. Résistance, bobine: 64ohm

### **V23092-12G Plug-in** PCB relay SCHRACK SNR, 12 V DC , 6 A

1. Electrical values
2. Switching voltage 400 V AC
3. Coil voltage 12 V DC
4. Switching current 6 A
5. Internal resistance (Ri) 848 Ohm
6. Isolation voltage 4000 V
7. Contacts AgSnO2
8. Measures
9. Length 28 mm
10. Width 5 mm



Georg Simon Ohm



James Prescott Joule